

**BGE**  
**STRATEGIC CUSTOMER ENGINEERING**

**PRIMARY CUSTOMER SUBSTATION REQUIREMENTS**  
**13.2 KV & 33 KV METAL-ENCLOSED SERVICE ENTRANCE SWITCHGEAR**

**GUIDE SPECIFICATION CSR-1**  
REVISION No. 10 – January 22, 2009

**TABLE OF CONTENTS**

1. GENERAL .....	2
2. BGE SUPPLY FEEDER .....	4
3. SWITCHGEAR ENCLOSURE AND ASSEMBLY .....	5
4. SITE REQUIREMENTS .....	7
5. LOAD INTERRUPTER SWITCH .....	8
6. POWER AND ELECTRONIC FUSE EQUIPMENT .....	10
7. FIXED MOUNTED (NON-DRAWOUT) CIRCUIT BREAKER .....	12
8. MAIN AND GROUND BUS .....	14
9. GROUNDING DEVICES .....	16
10. BGE REVENUE METERING UNIT .....	17
11. AUTOMATIC TRANSFER OPERATION .....	23
12. SUBSTATION GROUNDING SYSTEM .....	28
13. TRANSFORMER .....	29
14. SHORT-CIRCUIT AND COORDINATION STUDY .....	30
15. INSPECTIONS AND TESTS .....	30
16. REQUIRED SUBMITTALS .....	32
17. SCHEDULING & OUTAGES .....	33
18. TYPICAL ARRANGEMENTS AND DETAILS .....	34

**BGE**  
**STRATEGIC CUSTOMER ENGINEERING**

**PRIMARY CUSTOMER SUBSTATION REQUIREMENTS**  
**13.2 KV & 33 KV METAL-ENCLOSED SERVICE ENTRANCE SWITCHGEAR**

**GUIDE SPECIFICATION CSR-1**  
REVISION No. 10 – January 22, 2009

**1. GENERAL**

- 1.1. This Guide Specification describes the requirements for the design and installation of **METAL-ENCLOSED INTERRUPTER SWITCHGEAR** used as 13.2kV or 33kV primary service entrance equipment by Customers on the BGE system.
- 1.2. Please take note of the required submittals throughout this specification.
- 1.3. The supply voltage at each specific Customer substation shall be determined by BGE, depending on the Customer load requirements and available supply feeder or feeders at the Customer substation location. The Customer shall consult BGE for specific supply voltage requirements prior to proceeding.
- 1.4. These specifications cover the minimum BGE requirements. Specific installations may require modifications to these specifications. The Customer may elect to provide a greater level of protection. Requests for exceptions to BGE requirements shall be made in writing, clearly indicating the specific requirement and the proposed alternative. BGE will respond in writing to the requested exception.
- 1.5. The equipment shall meet all applicable requirements of ANSI, OSHA, IEEE, NEMA, National Electrical Code (NEC), National Electrical Safety Code (NESC), local codes, and BGE. Where applicable, the equipment shall be Underwriters Laboratories (UL) listed. The requirements of BGE are in addition to and in no way a waiver of the applicable standards and codes.
- 1.6. **REQUIRED SUBMITTAL:** Contract drawings and specifications covering the Customer substation installation, including the service entrance switchgear shall be submitted to BGE for review and approval prior to their release for contractual bidding. Drawings submitted to BGE shall include one-line diagram, plan details of the switchgear installation, and grounding system.
- 1.7. **REQUIRED SUBMITTAL:** Manufacturer shop drawings for the entire service entrance switchgear assembly shall be submitted to BGE for review and approval prior to fabrication of the switchgear. This review and approval may take up to six weeks and could affect the in-service date if shop drawings are not submitted to BGE in a timely manner for proper and comprehensive review by BGE. BGE will review partial or preliminary design drawings as a courtesy, but final drawings are required for BGE's approval.
- 1.8. **REQUIRED SUBMITTAL:** A short-circuit and coordination study shall be prepared by the Customer and submitted to BGE for review and approval. The coordination study shall indicate the ampere rating and time-current characteristics of the proposed power or electronic fuses on the outgoing feeders, or settings of the overcurrent relays on fixed mounted circuit breakers on the outgoing feeders, if applicable, which are subject to BGE approval. Available short-circuit current at the Customer primary service entrance equipment and BGE supply feeder overcurrent relay settings will be furnished by BGE upon request by the Customer.
- 1.9. Where parallel operation of Customer owned generation equipment is being considered the Customer shall contact BGE at the onset of planning. BGE has separate Customer generation

**BGE**  
**STRATEGIC CUSTOMER ENGINEERING**

**PRIMARY CUSTOMER SUBSTATION REQUIREMENTS**  
**13.2 KV & 33 KV METAL-ENCLOSED SERVICE ENTRANCE SWITCHGEAR**

**GUIDE SPECIFICATION CSR-1**

REVISION No. 10 – January 22, 2009

requirements for paralleling operation with the BGE system. Parallel operation of Customer owned generation with the BGE system, regardless of the voltage application, is subject to approval by BGE.

- 1.10. The connection of Customer equipment to the BGE system shall not reduce the quality of service to other Customers. No abnormal voltages, frequencies, harmonics, or service interruptions will be permitted.
- 1.11. BGE primary supply feeders shall not be paralleled by the Customer at any time.
- 1.12. Arrangements shall be made for ready access to the Customer substation and BGE revenue metering equipment by BGE personnel whenever it is required in performance of their duties. An “Access Notification” form must be completed by the Customer.
- 1.13. The Customer shall provide master-keyed padlocks for the substation access door, all load interrupter switch operating handles and the doors of all switchgear units, except the BGE metering unit door - the locks for this door will be provided by BGE. One key shall be located in a padlockable metal keybox. The keybox shall have a hinged cover with suitable provisions for padlocking by BGE. The keybox will be provided by BGE and mounted by the Customer outside the substation, adjacent to the access door.
- 1.14. All of the Customer load, including station service load, must be connected on the load side of the revenue metering. Where required for operation of an automatic transfer system, incoming voltage sensing potential devices or fused potential transformers will be permitted on the line side of the revenue metering, provided their installation meets applicable BGE requirements included in this specification.
- 1.15. A telephone line for remote revenue meter reading by BGE shall be provided by the Customer in accordance with this specification. In addition to the telephone line required for remote revenue metering, it is strongly recommended that the Customer substation be equipped with a telephone to facilitate communication during start-up, switching, or emergencies.
- 1.16. One-line wiring diagrams of typical metal-enclosed primary service entrance switchgear arrangements are included in these specifications.
- 1.17. A listing of Manufacturers of metal-enclosed switchgear currently approved by BGE is available upon request.
- 1.18. A minimum operating aisle of 8’-0” shall be provided in front of the switchgear, and on the rear of the switchgear where rear access is required for the operations of any switch or fuse equipment.

**2. BGE SUPPLY FEEDER**

**BGE**  
**STRATEGIC CUSTOMER ENGINEERING**

**PRIMARY CUSTOMER SUBSTATION REQUIREMENTS**  
**13.2 KV & 33 KV METAL-ENCLOSED SERVICE ENTRANCE SWITCHGEAR**

**GUIDE SPECIFICATION CSR-1**

REVISION No. 10 – January 22, 2009

- 2.1. The service connection between the proposed Customer substation and the BGE supply feeder or feeders shall be installed in accordance with BGE Electric Service Rules and Regulations, and the Maryland Public Service Commission.
- 2.2. **REQUIRED SUBMITTAL:** All conduit, duct banks, pull boxes, manholes, supports, etc., which may be required to carry the incoming primary voltage supply feeders from the point where they enter the Customer property to the point at which they terminate in the incoming unit of the Customer service entrance switchgear, shall be furnished and installed by the Customer subject to BGE approval.
- 2.3. Where applicable, BGE will direct bury the service cables within the Customer property or in public space. If direct buried conduits or concrete encased duct banks are required by the Customer or by the local jurisdiction outside the Customer property, the Customer shall install the necessary conduit or duct bank subject to BGE approval. BGE will install the service cables in the conduits provided by the Customer and pull the cables into the service entrance switchgear incoming unit.
- 2.4. Minimum conduit size shall be six-inch diameter. Five-inch diameter conduit may be acceptable for 13.2kV supply at some locations, subject to BGE approval. No more than the equivalent of two 90 degree bends will be permitted in any conduit run. Fabricated 90-degree elbows to terminate the conduits in the Customer incoming unit shall have a minimum bending radius of 48", unless otherwise approved by BGE.
- 2.5. The preferred conduit material is non-metallic PVC. Metallic conduit may be acceptable at some locations, subject to BGE approval. PVC conduit inserts may be required by BGE in metallic conduits, depending on the size of the service cables and the length of the supply cable pull.
- 2.6. The incoming supply feeders may enter the switchgear incoming unit from either the top or the bottom, depending upon the Customer requirements. Top cable entry will require switchgear modifications or installation of a cable trough below the switchgear unit with top entry.
  - 2.6.1. Where the incoming supply feeders enter from the bottom, two incoming conduits, one active and one spare, shall be provided by the Customer in the incoming unit. Where parallel supply feeder cables are required, four conduits shall be provided, two active and two spare.
  - 2.6.2. Where the incoming supply feeders enter from the top, the conduit installation shall meet the approval of the local electrical inspection authority having jurisdiction. One spare conduit shall be provided for each active conduit. Use of an 11 gauge steel pull box may negate the need for the second conduit to the switchgear for top entry applications.
- 2.7. Incoming supply feeder cables and terminations will be furnished and installed by BGE. The Customer's switchgear should be designed to accommodate NEMA-standard 2-hole terminal lugs. Cable supports shall be provided by the Customer as required.

**BGE**  
**STRATEGIC CUSTOMER ENGINEERING**

**PRIMARY CUSTOMER SUBSTATION REQUIREMENTS**  
**13.2 KV & 33 KV METAL-ENCLOSED SERVICE ENTRANCE SWITCHGEAR**

**GUIDE SPECIFICATION CSR-1**  
REVISION No. 10 – January 22, 2009

- 2.8. The manufacturer shall provide suitable ground bails at the point where the BGE incoming cable terminates to the switchgear. The cable must be removable without disturbing the ground bail. For details of the ground bail see Figure 10 in this document. Other ground bail designs may be submitted to BGE for approval. This must be by separate and specific submittal and done prior to manufacture.

**3. SWITCHGEAR ENCLOSURE AND ASSEMBLY**

- 3.1. The switchgear assembly shall consist of free-standing, self-supporting units containing but not limited to such devices as load interrupter switches, power or electronic fuses, fixed mounted power circuit breakers, revenue metering equipment, current transformers for overcurrent blocking of automatic transfer operation or fixed mounted power breaker overcurrent protection, incoming voltage monitoring potential devices or fused potential transformers, and fused control power transformers, as may apply to the specific Customer substation. Where applicable, provisions shall be made for extension to future switchgear units.
- 3.2. The switchgear enclosure shall have a rigid self-supporting structural steel framework. All framework shall be covered with not less than 11-gauge sheet steel, free from cracks, dent, seams, and other defects. The sheet steel covering the exterior of individual units shall be designed to insure complete isolation between adjacent circuits when the units are attached to adjacent units. All equipment requiring inspection or servicing shall be accessible by means of interior doors or plates to access the equipment or interconnecting bus.
- 3.3. Switchgear units containing expulsion type power fuses shall be designed in accordance with the minimum construction specifications of the fuse Manufacturer, providing adequate space for fuse handling and venting, and with sufficient rigidity and holding strength of enclosure, doors, windows, etc., for expulsion type power fuse exhaust.
- 3.4. Each unit shall be provided with front doors. Doors shall also be provided where access to the rear of the unit is required. Doors shall be fabricated from 11-gauge sheet steel minimum, with concealed hinges, three point latching system and foot operated door holders. Padlockable pistol grip door handles shall be provided. Inspection windows of adequate size shall be provided in the door in front of each load interrupter so that the open and closed positions of the switch can be readily observed from the outside of the switchgear.
- 3.5. Each unit or compartment in the switchgear assembly housing high voltage components shall be provided with an interior protective hinged screen barrier to prevent inadvertent physical contact with any energized part when the enclosure door is open. The hinged screen barrier shall be bolted closed with captive levers or other acceptable latching devices.
- 3.6. Screen barriers in front of the load interrupter switches shall be equipped with signs warning that “**SWITCH BLADES MAY BE ENERGIZED IN ANY POSITION**”. Screen barriers in front of power fuses or electronic fuses shall be equipped with signs warning that “**FUSES MAY BE ENERGIZED BY BACKFEED IN ANY POSITION**”. These warning signs are in addition to any other high voltage warning signs provided by the Manufacturer on the external and/or interior doors or barriers.

**BGE**  
**STRATEGIC CUSTOMER ENGINEERING**

**PRIMARY CUSTOMER SUBSTATION REQUIREMENTS**  
**13.2 KV & 33 KV METAL-ENCLOSED SERVICE ENTRANCE SWITCHGEAR**

**GUIDE SPECIFICATION CSR-1**

REVISION No. 10 – January 22, 2009

- 3.7. Key or mechanical interlocks shall be provided to prevent opening the door of the load interrupter switch units unless the switch is in the open position, or closing the switch if the door is open, except on the incoming load interrupter switch units where the interlocks shall be as specified below.
- 3.8. On the incoming load interrupter switch units, except where motor operated switches are provided, the key or mechanical interlocks shall allow opening the door of the incoming load interrupter switch units with the switch in any position, but shall prevent operating the switch with the door open.
- 3.9. Where motor operated switches are provided, an electric interlock shall be provided on the door of the switch compartment to prevent any electrical operation of the motor operated switch when the door is open.
- 3.10. Key or mechanical interlocks shall be provided to prevent opening the door of the power or electronic fuse compartment units, or the fixed mounted power circuit breaker compartment units, unless the associated load interrupter switch is in the open position, or closing the switch if the door is open.
- 3.11. Where fixed mounted power circuit breakers are installed, key interlocks shall be provided to prevent operating the associated load interrupter switch unless the power circuit breaker is in the open position.
- 3.12. Removable brackets shall be provided in each incoming supply feeder load interrupter switch unit for the installation three (3) BGE surge arresters. Arresters will be furnished and installed by BGE. The location of the arresters shall not interfere with the installation by BGE of the incoming supply feeder cable terminations.
  - 3.12.1. The manufacturer is responsible for providing the tap wire from the bus connection to the surge arrester.
  - 3.12.2. For 13.2kV service, BGE surge arresters will be 10kV duty cycle, 8.4 kV MCOV metal-oxide distribution class.
  - 3.12.3. For 33kV service, BGE surge arresters will be 30kV duty cycle, 24.4kV MCOV metal-oxide distribution class.
  - 3.12.4. Details of the surge arresters mounting provisions shall be shown on the switchgear drawings.
  - 3.12.5. Mounting details of the BGE surge arresters are included in this specification.
- 3.13. Each switchgear unit shall be equipped with screened ventilation louvers as required, in accordance with the Manufacturer design of the switchgear assembly.

**BGE**  
**STRATEGIC CUSTOMER ENGINEERING**

**PRIMARY CUSTOMER SUBSTATION REQUIREMENTS**  
**13.2 KV & 33 KV METAL-ENCLOSED SERVICE ENTRANCE SWITCHGEAR**

**GUIDE SPECIFICATION CSR-1**

REVISION No. 10 – January 22, 2009

- 3.14. Protective covers shall be provided over all key interlocks to protect keys from weather or accidental breaking.
- 3.15. Each incoming cubicle (bay) of switchgear shall be labeled with a minimum of one sign located above the switch operating handle that states **“INCOMING UTILITY FEEDER”**
- 3.16. Each outgoing cubicle (bay) of switchgear shall be labeled with a minimum of one sign located above the switch operating handle that states **“OUTGOING FEEDER TO CUSTOMER’S LOAD”**
- 3.17. Each revenue metering cubicle (bay) of switchgear shall be labeled with a minimum of one sign located in the center of the main door that states: **“UTILITY REVENUE METERING”**
- 3.18. Each cubicle of switchgear (bay) of switchgear that contains potential transformer(s) or potential transformer fuses shall be labeled with a minimum of one sign in the middle of the door that states”  
**“POTENTIAL TRANSFORMERS”** or **“POTENTIAL TRANSFORMER FUSES”**
- 3.19. If a mimic bus is to be included on the front of the switchgear a separate drawing must be submitted to BGE for approval.

**4. Site Requirements**

**4.1. Indoor Installations**

- 4.1.1. A 3.5” concrete housekeeping pad shall be provided
- 4.1.2. Two means of egress from the switchgear room shall be provided
- 4.1.3. BGE will supply a key box to be mounted on the outside of the switchgear room personnel door. The Customer will provide a door key to be stored in this box. BGE will lock the box with our lock.

**4.2. Outdoor Installations**

- 4.2.1. The entire switchgear assembly shall be of outdoor construction and all doors and joints between units shall be equipped with gaskets of suitable material to prevent moisture from entering the enclosure.
- 4.2.2. Outdoor switchgear units shall be equipped with heaters to maintain air circulation and prevent condensation inside the enclosure. Heaters shall be equipped with guards providing both thermal and electric shock protection to personnel. Heater wiring must be of the type capable of withstanding the high temperature environment in the proximity of the heaters.

**BGE**  
**STRATEGIC CUSTOMER ENGINEERING**

**PRIMARY CUSTOMER SUBSTATION REQUIREMENTS**  
**13.2 KV & 33 KV METAL-ENCLOSED SERVICE ENTRANCE SWITCHGEAR**

**GUIDE SPECIFICATION CSR-1**

REVISION No. 10 – January 22, 2009

- 4.2.3. Heaters shall be wired to one main fused safety switch or circuit breaker located in steel enclosed compartments in the front of a switchgear unit. An access cover shall be provided to allow operation of the heater switch or breaker while the switchgear is energized.
- 4.2.4. Heaters shall operate continually without the application of a thermostat, unless a humidistat is also provided in the heater control to operate the heaters during high humidity weather regardless of temperature.
- 4.2.5. Louvers on each outdoor switchgear unit shall be equipped with inside screens and baffle plates to guard against the entrance of insects, rodents, water, etc.
- 4.2.6. Protective covers shall be provided over the cylinder locks of the key interlock systems to protect keys from weather and accidental breaking.
- 4.2.7. The outdoor switchgear assembly shall be of anti-vandalism construction capable of providing protection against contact with enclosed equipment that would be subject to deliberate unauthorized acts by unsupervised general public in installations where a protective fence enclosure is not provided.
- 4.2.8. Padlockable anti-vandalism steel covers shall be provided over all switch operating handles, key interlock devices and viewing windows.
- 4.2.9. A concrete pad shall be provided to adequately support the service entrance switchgear. An adequate standing area shall be provided in front of the switchgear for personnel to operate the switchgear. This may either be an extension of the concrete pad or crushed stone brought to the same level as the concrete pad. Grass, dirt or other such slippery surfaces may not be used.
- 4.2.10. Where a **substation fence** is specified, the fence shall be 8' high minimum, made of 7' metal fabric and topped with a 1' height of barbed wire, unless otherwise approved by BGE.
- 4.2.11. A 3'-0" personnel gate shall be provided and shall be equipped with double padlocking facilities. **NOTE:** Two means of egress must be provided and maintained.
- 4.2.12. The substation fence shall be connected to the substation grounding system in accordance with Section 12 in this specification.
- 4.2.13. High voltage warning signs shall be provided on each access gate and on all sides of the fence enclosure.
- 4.2.14. Where applicable, the fenced area in outdoor substations shall be filled with 3/4" crushed stone to a minimum depth of 4". The top of the stone shall be approximately level with the top of the concrete pad supporting the switchgear.
- 4.2.15. Where the substation is located adjacent to roadways, loading docks, parking areas, or any area susceptible to damage from vehicular traffic, pipe guards, or barriers shall be installed

**BGE**  
**STRATEGIC CUSTOMER ENGINEERING**

**PRIMARY CUSTOMER SUBSTATION REQUIREMENTS**  
**13.2 KV & 33 KV METAL-ENCLOSED SERVICE ENTRANCE SWITCHGEAR**

**GUIDE SPECIFICATION CSR-1**  
REVISION No. 10 – January 22, 2009

around the substation area to protect the fence or the electrical equipment. The pipe guards or barriers shall not interfere with the operation of the switches or opening the doors of the switchgear units. Metal pipes shall be connected to the substation grounding system in accordance with Section 12 in this specification.

**5. LOAD INTERRUPTER SWITCH**

- 5.1. Load interrupter switches shall be 3-pole group operated load interrupter air switches. Manually operated switches shall be equipped with an external non-removable operating handle with padlocking facilities in either open or closed position. Motor operated switches shall be equipped with electric motor operators compatible with the load interrupter switch.
- 5.2. Load interrupter switches shall meet the requirements of BGE for application as load interrupter switches in 13.2kV and 33kV metal-enclosed service entrance switchgear.
- 5.3. Load interrupter switches shall be equipped with a quick-make, quick-break stored energy device to insure high-speed closing and opening of the switch independent of the speed of the operating handle.
- 5.4. The incoming feeder, load interrupter switch shall be installed in a separate switchgear unit.
  - 5.4.1. The incoming load interrupter switch shall be mounted to receive the BGE incoming supply cables on the hinged end at the bottom of the switch, with the jaw end of the switch at the top connected to the switchgear main bus. No other equipment, except the BGE surge arresters, grounding devices, current transformers (for automatic transfer system), and BGE cable terminations shall be installed in the incoming switch unit.
  - 5.4.2. Grounding devices shall be provided on the hinged end of the incoming load interrupter switch in accordance with Section 8 in this specification.
  - 5.4.3. Typical details of the incoming feeder load interrupter switch unit are included in this specification.
- 5.5. Where applicable for split-bus arrangement with two supply feeders, a bus tie load interrupter switch shall be provided in a separate switchgear unit.
  - 5.5.1. It is strongly recommended that a second manually operated bus tie load interrupter switch be provided in the switchgear assembly to facilitate switchgear maintenance. This second bus tie load interrupter switch will be operated as a normally closed “Maintenance Switch”.
  - 5.5.2. The normally closed manual maintenance switch would be required to allow periodic maintenance of the bus tie load interrupter switch without having to de-energize the entire switchgear assembly. With the maintenance switch open, it is possible to maintain the bus tie switch with only half of the switchgear bus de-energized. This manually operated maintenance switch is particularly important when automatic transfer operation is provided between the two motor-operated incoming switches and the motor operated bus tie switch.

**BGE**  
**STRATEGIC CUSTOMER ENGINEERING**

**PRIMARY CUSTOMER SUBSTATION REQUIREMENTS**  
**13.2 KV & 33 KV METAL-ENCLOSED SERVICE ENTRANCE SWITCHGEAR**

**GUIDE SPECIFICATION CSR-1**

REVISION No. 10 – January 22, 2009

- 5.6. Where two BGE supply feeders are installed, the associated main incoming switches and the bus tie load interrupter switch, if applicable, shall be interlocked to prevent paralleling the two supply feeders.
- 5.6.1. Key interlocks shall be provided on manually operated switches to prevent paralleling the two supply feeders.
- 5.6.2. Electrical and key interlocks shall be provided on motor operated switches to prevent paralleling the two supply feeders.
- 5.7. Interphase Barriers shall be provided to isolate each switch pole blade in any position with no less than 5-inch overlap all around. Barriers shall be sturdily mounted to prevent misalignment or incidental contact with any energized part.
- 5.8. **Load interrupter switches** shall have the following ratings:

	<b><u>13.2 kV</u></b> <b><u>Service</u></b>	<b><u>33 kV</u></b> <b><u>Service</u></b>
Nominal service voltage class, kV, rms	13.2	33.0
Rated maximum voltage, kV, rms	15.0	38.0
Insulation levels, rated withstand voltage:		
Low frequency, kV, rms; not less than	36	80
Impulse (BIL), kV, crest; not less than	95	150
Rated frequency, hertz	60	60
Rated continuous current, amperes	600 or 1200	600 or 1200
Rated load interrupter current, amperes	600 or 1200	600 or 1200
Closing and Latching Capability, kA Asym, crest	40	40
Short time current ratings:		
Momentary, kA asymmetrical, rms	40	40
3-Second, kA rms, symmetrical	23	25

- 5.9. Manufacturers of load interrupter switches currently approved by BGE for application in metal-enclosed service entrance switchgear are:
- S&C Electric Company – “Alduti-Rupter” (13.2kV & 33kV)  
S&C Electric Company – “Mini-Rupter” (13.2kV)  
Powercon Corporation – “PIF” (13.2kV & 33kV)  
Cutler-Hammer Company – “WLI” (13.2kV & 33kV)  
Square D Company – “HVL” (13.2kV & 33kV)
- 5.9.1. Other load interrupter switch Manufacturers will be considered subject to factory and/or field inspections, and certified test data and drawing review and approval by BGE prior to awarding an order to a switch Manufacturer not on the BGE approved list.

**BGE**  
**STRATEGIC CUSTOMER ENGINEERING**

**PRIMARY CUSTOMER SUBSTATION REQUIREMENTS**  
**13.2 KV & 33 KV METAL-ENCLOSED SERVICE ENTRANCE SWITCHGEAR**

**GUIDE SPECIFICATION CSR-1**  
REVISION No. 10 – January 22, 2009

**6. POWER AND ELECTRONIC FUSE EQUIPMENT**

- 6.1. Power fuses for use in 13.2kV or 33kV metal-enclosed interrupter switchgear shall be of solid-material expulsion type utilizing refill-unit-holder of fuse-unit-end-fitting construction. Fuse holder shall be equipped with snuffler, silencer, or discharge filter-condenser, depending of fuse Manufacturer type.
- 6.2. Power fuse minimum short-circuit interrupting capacity shall be in accordance with the ratings in section 6.8. For optimum coordination with upstream BGE protective devices, outgoing feeders should be designed for a maximum 125E Amp. “STD” fuse refills. Fuse ratings higher than 125E Amperes must be approved by BGE, to verify coordination with BGE protective devices. Electronic fuses may be required.
- 6.3. Electronic fuses for use in 13.2 kV metal-enclosed interrupter switchgear shall utilize an expendable interrupting module and a reusable control module. The interrupting module shall consist of a main current section and a fault-interrupting section. The control module shall provide for time-delayed compound-curve or inverse-curve time-current characteristics and four different minimum pickup settings from 400 amperes to 1100 amperes.
- 6.4. Proposed electronic fuse time-current characteristics and minimum pickup settings shall be approved by BGE.
- 6.5. All power and electronic fuses shall be equipped with 45 degree disconnect type mounting and live part equipment. Adequate clearance shall be maintained through the entire arc traveled by the fuse to its open position as if the fuse was energized.
- 6.6. Grounding devices shall be provided on the outgoing feeder power and electronic fuses in accordance with Section 9 in this specification.
- 6.7. Interphase barriers shall be provided to isolate each fuse unit in any position with no less than 5-inch overlap all around. Barriers shall be sturdily mounted to prevent misalignment or incidental contact with any energized part.
- 6.8. **Power fuses** shall have the following ratings:

	<b><u>13.2 kV</u></b> <b><u>Service</u></b>	<b><u>33kV</u></b> <b><u>Service</u></b>
Nominal service voltage class, kV, rms	13.2	33
Nominal fuse rated voltage, kV, rms	13.8	34.5
Rated frequency, hertz	60	60
Fuse holder maximum continuous current, amperes	400	300
Minimum short-circuit interrupting rating:		
Symmetrical kA, rms	25	17.5
Asymmetrical kA, rms	40	28



**BGE**  
**STRATEGIC CUSTOMER ENGINEERING**

**PRIMARY CUSTOMER SUBSTATION REQUIREMENTS**  
**13.2 KV & 33 KV METAL-ENCLOSED SERVICE ENTRANCE SWITCHGEAR**

**GUIDE SPECIFICATION CSR-1**

REVISION No. 10 – January 22, 2009

**7. FIXED MOUNTED (NON-DRAWOUT) CIRCUIT BREAKER**

- 7.1. As an alternate to “electronic fuses”, a fixed-mounted (non-drawout) circuit breaker may be used, provided that a load interrupter switch shall be installed ahead of the circuit breaker in the same switchgear unit. If fixed-mounted circuit breakers are used for outgoing feeder protection, main incoming feeder fixed-mounted circuit breakers must also be installed in lieu of the standard load interrupter switches used in traditional metal-enclosed switchgear installations. The load interrupter switch used with the fixed mounted circuit breaker shall be in accordance with Section 4 above. The load interrupter switch is required to provide a visible break on the fixed-mounted breaker circuit.
- 7.2. Fixed-mounted circuit breakers shall be air-magnetic, vacuum, or SF6 insulated, 3-pole, single-throw, electrically operated, having mechanical stored energy operating mechanisms. Breakers shall be designed for service on a three phase, 60 Hz system. The continuous current capacity of the breakers shall be as required to satisfactorily operate within the specified duties. Breakers shall be equipped with a manual operating device for manually closing and manually opening the contacts. A mechanical position indicator and an operation counter shall be furnished for each breaker. When SF6 interrupter bottles are furnished, a low-pressure alarm switch shall be furnished for each interrupter bottle.
- 7.3. A key-interlock shall be provided to prevent opening the load-interrupter switch unless the circuit breaker is in the open position.
- 7.4. A second key-interlock shall be provided on the incoming feeder load interrupter switch operating mechanism. This key-interlock shall have the key captive with the switch in the closed position. This interlock prevents closing the load interrupter switch with the key removed and is intended to prevent accidentally back-feeding the incoming feeder during feeder maintenance.
- 7.5. **Circuit breakers** shall have the following ratings:

	<b><u>13.2kV</u></b>	<b><u>33kV</u></b>
	<b><u>Service</u></b>	<b><u>Service</u></b>
Nominal voltage class, kV, rms	13.2	33
Rated maximum voltage, kV, rms	15.0	38.0
Nominal 3-Phase MVA Class, MVA, not less than	500	1500
Rated voltage range factor, kV	1.3	1.0
Insulated levels, rated withstand voltage:		
Low frequency, kV, rms	36	80
Impulse, kV, crest	95	150
Rated frequency, hertz	60	60
Rated maximum interrupting time (60 Hz base), cycles	5	5
Rated continuous current, amperes	1200	1200
Rated short-circuit current, kA, rms, symmetrical	18	25
Maximum interrupting capacity, kA, rms, symmetrical	23	25

**BGE**  
**STRATEGIC CUSTOMER ENGINEERING**

**PRIMARY CUSTOMER SUBSTATION REQUIREMENTS**  
**13.2 KV & 33 KV METAL-ENCLOSED SERVICE ENTRANCE SWITCHGEAR**

**GUIDE SPECIFICATION CSR-1**

REVISION No. 10 – January 22, 2009

Three second short-time current carrying capability, kA, rms	23	35
Closing and latching capability, kA, rms	37	56

- 7.6. Circuit breakers shall be furnished with a stored energy operating mechanism mounted on the breaker frame. Breakers shall be trip-free and non-pumping. The breaker operating mechanism shall be designed for operation from one of the control power sources indicated below.
- 7.6.1. 48 or 125 volts, dc, for trip and close operation of the breaker, including battery and battery charger equipment. Customer must provide an AC source for the battery charger.
- 7.6.2. 120 volts, ac, for trip and close operation of the breaker, including a stored-energy capacitor trip device and fused potential or control power transformer.
- 7.6.3. For AC closing circuit breakers used as incoming feeder circuit breakers, fused potential transformers must be connected on the source side of the main incoming load interrupter switch. These transformers shall be mounted on a drawout carriage assembly in accordance with details supplied in this specification for drawout units.
- 7.6.4. For DC close and trip circuit breakers, a fixed mounted fused potential transformer or control power transformer may be connected on the load side of the main incoming load interrupter switch on the load side of the BGE metering equipment. BGE personnel will not replace the transformer fuses, or perform any operation on the fixed mounted potential or control power transformer connected on the switchgear bus. Transformers/fuses mounted on drawout carriages are preferred.
- 7.7. Current transformers shall be provided on each phase for breaker overcurrent protection. Current transformers shall have a suitable current ratio in accordance with the outgoing feeder load and the overcurrent relay characteristics.
- 7.8. Overcurrent protection for the fixed mounted circuit breaker shall be provided by inverse current type relays subject to approval by BGE. Time-current characteristic and settings shall be determined by the Customer's coordination study, and approved by BGE. Overcurrent relays shall be equipped with time and instantaneous trip.
- 7.8.1. Overcurrent relays shall be of the induction disc type or "electronic" type approved by BGE. Relay settings shall be provided by the Customer along with supporting evidence in the form of a Coordination Study to be submitted to BGE for approval. The Customer's contractor shall calibrate the overcurrent relays in accordance with the approved coordination study. BGE shall verify the settings via secondary current injection tests on the main incoming feeder circuit breakers.
- 7.8.2. The relays shall be mounted in a drawout case to facilitate current injection testing, or shall be installed with the appropriate current test switches to facilitate testing the relays by secondary current injection without removing the relays from their cases. The design of the test switch facilities shall be subject to BGE approval.

**BGE**  
**STRATEGIC CUSTOMER ENGINEERING**

**PRIMARY CUSTOMER SUBSTATION REQUIREMENTS**  
**13.2 KV & 33 KV METAL-ENCLOSED SERVICE ENTRANCE SWITCHGEAR**

**GUIDE SPECIFICATION CSR-1**

REVISION No. 10 – January 22, 2009

**8. MAIN AND GROUND BUS**

**8.1. Main Bus**

- 8.1.1. The main bus and taps shall have minimum rated continuous current of 600 or 1200 amperes, as required by the Customer load.
- 8.1.2. Main bus and taps shall be rigid, of high conductivity copper or aluminum, with all joints plated. All bus connections shall be made with at least two bolts not less than 3/8" diameter or one bolt not less than 1/2" diameter. All bolted bus connections shall be tightened to Manufacturer's specifications to insure maximum conductivity.
- 8.1.3. The phase arrangement of the switchgear assembly shall be A – B – C from left to right, top to bottom, and front to back, when looking at the front view of the switchgear. The phase arrangement of the switch and fuse poles, and all accessories shall be shown on the switchgear drawings.
- 8.1.4. Minimum phase-to-phase and phase-to-ground clearances of main bus and taps shall be determined by the BIL rating of the switchgear assembly. The switchgear Manufacturer shall furnish, upon request, certification of the BIL rating established by test to insure that clearances between bare live parts and between bare live parts and adjacent grounded surfaces are adequate for the BIL rating.
- 8.1.5. The minimum BIL rating of the switchgear assembly shall be 95kV impulse withstand for 13.2kV service and 150kV impulse withstand for 33kV service.
- 8.1.6. The minimum nominal 3-phase MVA Class of the switchgear assembly shall be 500MVA for 13.2kV service and 1000MVA for 33kV service.
- 8.1.7. All cable connections to the main bus or switches shall be made with standard NEMA two-bolt compression type connectors.
- 8.1.8. The switchgear shall be equipped with provisions for extension of the main bus to future switchgear units, as applicable.
- 8.1.9. The bus support insulators shall be capable of withstanding the short circuit stresses associated with the maximum momentary rms asymmetrical amperes rating of the switch and fuse equipment in the switchgear. Each bus section shall be supported at a minimum of two points to maintain alignment.
- 8.1.10. The temperature rise of buses and connections shall not exceed ANSI requirements. Provisions shall be made for expansion and contraction of buses due to temperature changes.

**8.2. Ground Bus**

**BGE**  
**STRATEGIC CUSTOMER ENGINEERING**

**PRIMARY CUSTOMER SUBSTATION REQUIREMENTS**  
**13.2 KV & 33 KV METAL-ENCLOSED SERVICE ENTRANCE SWITCHGEAR**

**GUIDE SPECIFICATION CSR-1**

REVISION No. 10 – January 22, 2009

- 8.2.1. A continuous copper or aluminum ground bus shall extend through and connect to all units of the switchgear assembly.
- 8.2.2. The ground bus shall be capable of withstanding the short circuit stresses associated with the maximum momentary rms asymmetrical amperes rating of the switch and fuse equipment in the switchgear. The ground bus shall not be smaller than 2" x 1/4" copper bar.
- 8.2.3. The ground bus shall be securely bonded and run through the entire switchgear assembly. Each section of the assembly shall be grounded directly to the switchgear ground bus.
- 8.2.4. Ground bus joints shall be plated and made with at least two bolts not less than 3/8" diameter or one bolt not less than 1/2" diameter. Provisions shall be made for extension of the ground bus to future switchgear units, as applicable.
- 8.2.5. The switchgear ground bus shall be connected at each end to the substation grounding system in accordance with Section 12 in this specification. The switchgear Manufacturer shall provide a minimum of two 2-hole NEMA drilled compression type terminal lugs, suitable for connection of a 4/0 AWG station grounding wire, for the Customer to make the ground connections to the substation grounding system.
- 8.2.6. The ground bus and respective ground connectors shall be capable of carrying the rated short-circuit current.
- 8.2.7. Ground connections shall be provided for all removable elements.
- 8.2.8. Where applicable, cases of frames of instruments, meters, relays, instrument transformers, and similar devices shall be considered as being adequately grounded when secured to the metal structure by metal mounting screws with adequate provision for penetrating the mounting structure paint film by the mounting hardware.

**9. GROUNDING DEVICES**

- 9.1. Grounding devices for the attachments of portable grounding equipment shall be provided where specified below. Grounding devices shall be approved by BGE.
  - 9.1.1. One grounding device per phase on the line side of each 13.2kV or 33kV incoming load interrupter switch.
  - 9.1.2. One grounding device per phase on the load side of each 13.2kV outgoing feeder fuse.
  - 9.1.3. Two grounding devices per phase, one on each side (line and load) of each 33kV outgoing feeder fuse.
  - 9.1.4. Two grounding devices per phase, one on each side (line and load) of each 13.2kV or 33kV revenue metering current transformer bus connection. The grounding device bus

**BGE**  
**STRATEGIC CUSTOMER ENGINEERING**

**PRIMARY CUSTOMER SUBSTATION REQUIREMENTS**  
**13.2 KV & 33 KV METAL-ENCLOSED SERVICE ENTRANCE SWITCHGEAR**

**GUIDE SPECIFICATION CSR-1**

REVISION No. 10 – January 22, 2009

connections shall be independent of the current transformer connections to the switchgear bus.

- 9.1.5. One grounding device per phase on the line side of the primary lead to each 13.2kV revenue metering potential transformer.
- 9.1.6. One grounding device on the switchgear ground bus, in front of each switchgear unit and in the revenue potential and current transformer compartments in the switchgear assembly.
- 9.2. Details of the grounding devices approved by BGE are included in these specifications (see “FIGURE 5”). Alternate designs will be considered subject to approval by BGE prior to fabrication and certified by test to withstand the short circuit stresses associated with the momentary rms asymmetrical rating of the switch and fuse equipment in the switchgear.

**10. BGE REVENUE METERING UNIT**

**10.1. General Requirements Metering Units**

- 10.1.1. The BGE revenue metering units in the switchgear assembly shall contain provisions for mounting the BGE revenue metering current and potential transformers, and potential transformer fuses, including all necessary drilling and bolting hardware.
- 10.1.2. Each metering unit shall be provided with front doors. Doors shall also be provided where access to the rear of the BGE metering cubicle is required. Doors shall be as specified in 3.4 above. Metering unit doors shall be equipped with pistol handles having provisions for padlocking. Padlocks for the metering unit doors will be furnished by BGE.
- 10.1.3. The revenue metering current transformers, potential transformers, and potential transformer fuses will be furnished and installed by BGE. The quantity, rating, make and type of the metering current transformers, potential transformers and potential transformer fuses will be specified by BGE for each Customer installation.
- 10.1.4. BGE will furnish and install three (3) current transformers, three (3) potential transformers, and three (3) potential transformer fuses (except as noted in 10.3.3.1 below) in each revenue-metering unit, unless otherwise specified by BGE for a particular Customer installation.
- 10.1.5. All primary connections from the switchgear bus to the current transformer terminals, from the switchgear bus to the potential transformer fuses, and from the fuses to the potential transformers shall be provided and installed by the switchgear Manufacturer.
- 10.1.6. Primary connections between the switchgear bus and the current transformers shall have the same continuous current rating as the main switchgear bus.

**BGE**  
**STRATEGIC CUSTOMER ENGINEERING**

**PRIMARY CUSTOMER SUBSTATION REQUIREMENTS**  
**13.2 KV & 33 KV METAL-ENCLOSED SERVICE ENTRANCE SWITCHGEAR**

**GUIDE SPECIFICATION CSR-1**

REVISION No. 10 – January 22, 2009

10.1.7. Primary taps from the switchgear bus to the potential transformer fuses shall be connected to the switchgear bus on the **supply** side terminals of the current transformer primary bus connections.

10.1.8. All primary cable connections to the switchgear bus shall be made **with two-bolt compression type connectors**.

**10.2. Grounding Requirements**

10.2.1. Grounding devices for the attachments of portable grounding equipment shall be provided where specified below. Grounding devices shall be approved by BGE.

10.2.2. Grounding devices on both sides of the 13.2kV or 33kV current transformer bus connections shall be provided. Grounding devices shall be readily accessible and securely attached to the switchgear bus so as not to interfere with, nor have to be removed during the installation, removal, or replacement of the current transformers.

10.2.3. Grounding devices on the primary leads from the potential transformer fuses to the 13.2kV or 33kV potential transformers shall be provided. Grounding devices shall be readily accessible and securely attached to bus supports so as not interfere with the installation, removal, or replacement of the potential transformers.

10.2.4. Grounding devices shall be provided on the ground bus, or ground bus extensions into the current or potential transformer compartments. Grounding devices shall be readily accessible and within the reach of the BGE portable ground leads to be attached by BGE on the grounding devices on both sides of the current transformers or on the primary leads to the potential transformers.

10.2.4.1. Details of the grounding devices are included in this specification. Alternate designs will be considered subject to approval by BGE prior to fabrication and certified by test to withstand the short circuit stresses associated with the short-circuit rating of the switchgear.

10.2.4.2. There shall be adequate clearance for the metering cubicle door to be closed with the portable ground leads in place.

**10.3. Drawout Fuse Unit**

10.3.1. A fuse drawout unit complete with fuse clips mounted on insulators shall be provided in a completely isolated compartment to accommodate three potential transformers fuses.

**BGE**  
**STRATEGIC CUSTOMER ENGINEERING**

**PRIMARY CUSTOMER SUBSTATION REQUIREMENTS**  
**13.2 KV & 33 KV METAL-ENCLOSED SERVICE ENTRANCE SWITCHGEAR**

**GUIDE SPECIFICATION CSR-1**

REVISION No. 10 – January 22, 2009

- 10.3.2. Fuse clips for 13.2kV service shall be mounted on 11-1/2” centers to accommodate current limiting fuses having 1-9/16” diameter ferrules, similar to GE “EJ-1”, Size “B”, 15kV, 1.0E ampere.
- 10.3.3. Fuse clips for 33kV service shall be mounted on 27” centers to accommodate current limiting fuses having 3” diameter ferrules, similar to GE “EJO-1”, Size “D”, 38kV, 5.0E amperes.
- 10.3.3.1. Manufacturers supplying a fuse drawout unit that utilizes fuses other than those specified in 10.3.3 above shall provide three fuses and three spares for each fuse drawout unit provided. A storage pocket shall be provided in the main door of each metering unit.
- 10.3.4. When fuses in the drawout unit are mounted horizontally, they shall be not more than 5’ above finished floor. If mounted vertically, the top fuse clip shall not be more than 6’ above finished floor.
- 10.3.5. The fuse drawout unit shall latch in both the fully withdrawn position and fully closed position.
- 10.3.6. The fuse drawout unit shall be designed so that all contacts will be disconnected from the energized circuits before the fuses become accessible. Both ends of the fuses shall be visibly grounded when the drawout unit is in the fully withdrawn and latched position.
- 10.3.7. **For metal-clad switchgear applications** automatic shutters shall be provided to isolate the drawout unit from the bus connection in the compartment. The shutters shall open when the fuse drawout unit moves forward into the connected position, and shall close when the drawout unit is withdrawn.
- 10.3.8. The metal frame of the drawout unit shall be grounded in all positions.
- 10.3.9. The fuse drawout unit grounding facilities shall be approved by BGE prior to fabrication. Grounding facilities shall provide a positive ground connection with the unit in the fully and latched position. Braided grounding straps, which merely brush the fuse primary terminals, are not acceptable. Shop drawings shall show sufficient details of the grounding facilities. Field approval by BGE of the fuse drawout unit grounding facilities shall be required prior to energizing the service entrance switchgear.
- 10.3.10. The front of the drawout unit shall be solid with no venting, louvers, or openings and provide padlocking facilities, unless the drawout unit assembly is located behind a padlockable door.
- 10.3.11. The switchgear ground bus shall be extended and mounted in the front of each current and potential transformer compartment. A grounding device shall be mounted on the ground bus extension in each compartment.

**BGE**  
**STRATEGIC CUSTOMER ENGINEERING**

**PRIMARY CUSTOMER SUBSTATION REQUIREMENTS**  
**13.2 KV & 33 KV METAL-ENCLOSED SERVICE ENTRANCE SWITCHGEAR**

**GUIDE SPECIFICATION CSR-1**

REVISION No. 10 – January 22, 2009

10.3.12. Should interphase barriers be necessary to isolate each fuse unit they shall have no less than 6 inch overlap all around. Barriers shall not interfere with the application of grounds on both ends of the fuse and shall be sturdily mounted to prevent misalignment or incidental contact with any energized part.

**10.4. 13.2kV Metering Unit**

10.4.1. Three (3) Current Transformers will be provided by BGE for revenue metering of each 13.2kV incoming supply feeder. The BGE revenue metering current transformers will have the same dimensions as the GE type JKM-5.

10.4.2. A completely isolated compartment shall be provided in the metering unit for the installation by BGE of the three revenue metering current transformers.

10.4.3. Three (3) Potential Transformers will be provided by BGE for revenue metering of each 13.2kV incoming supply feeder. The BGE revenue metering potential transformers will have the same dimensions as the GE type JVM-5.

10.4.4. A completely isolated compartment shall be provided in the metering unit for the installation by BGE of the three revenue metering potential transformers.

10.4.5. The compartments shall be arranged to allow for the easy access, installation, removal, or replacement of the revenue metering current and potential transformers after the metering unit is installed as an integral part of the switchgear assembly.

10.4.6. Each metering unit compartment housing the potential and current transformers shall be provided with an interior protective hinged screen barrier or metal panel to prevent inadvertent physical contact with any energized part with the metering cubicle door open. The interior hinged screen barrier or metal panels shall be bolted closed with captive fasteners or other acceptable latching devices.

10.4.7. Grounding devices shall be provided in accordance with Section 10.2 above.

10.4.8. The switchgear ground bus shall be extended and mounted in the front of each current and potential transformer compartment. A grounding device shall be mounted on the ground bus extension in each compartment.

10.4.9. Three (3) current limiting fuses will be provided by BGE for protection of each revenue metering potential transformer (13 kV metering only).

10.4.10. Typical arrangement of the 13.2kV metering cubicle is included in this specification.

**10.5. 33kV Metering Unit**

**BGE**  
**STRATEGIC CUSTOMER ENGINEERING**

**PRIMARY CUSTOMER SUBSTATION REQUIREMENTS**  
**13.2 KV & 33 KV METAL-ENCLOSED SERVICE ENTRANCE SWITCHGEAR**

**GUIDE SPECIFICATION CSR-1**

REVISION No. 10 – January 22, 2009

- 10.5.1. Three (3) Current Transformers will be provided by BGE for revenue metering of each 33kV incoming supply feeder. The BGE revenue metering current transformers will be similar to GE type JKW-7.
- 10.5.2. Three (3) Potential Transformers will be provided by BGE for revenue metering for each 33kV incoming supply feeder. The BGE revenue metering potential transformers will be similar to GE JVW-7.
- 10.5.3. Arrangement of the revenue-metering unit shall allow for easy access, installation, removal, or replacement for the revenue metering current and potential transformers by BGE after the metering unit is installed as an integral part of the switchgear assembly.
- 10.5.4. The metering unit shall be provided with an interior protective hinged screen barrier to prevent inadvertent physical contact with any energized part with the metering cubicle door open. In lieu of this second barrier separate isolated compartments may be provided for the current and potential transformers. These compartments must be supplied with a latchable door.
- 10.5.5. The interior hinged screen barrier shall be bolted closed with captive fasteners or other acceptable latching devices.
- 10.5.6. Typical arrangement of the 33kV metering cubicle is included in this specification.

**10.6. Secondary Wiring**

- 10.6.1. Secondary wiring from the current and potential transformers shall be provided by the switchgear manufacturer. Secondary wiring shall be extended and connected to terminal blocks in each metering unit. Adequate slack shall be provided for BGE to make the final connections to the metering transformers secondary terminals.
- 10.6.2. Secondary wiring shall be type SIS or approved equal, stranded, insulated switchboard wire of minimum #12 AWG. Wires shall be equipped with ring tongue type terminals and terminated at the associated terminal blocks. Wiring shall be installed in metal conduit extending to each CT and PT terminals or be shielded, bundled, and appropriately supported to the compartment walls. If conduit is used it must be extended all the way to the individual terminal points of the transformers. The intent here is to prevent exposure of low voltage wiring in the high voltage compartment. Insulating bushings are to be installed when wiring between adjacent compartments or through barriers and partitions.
- 10.6.3. All six secondary leads from each set of metering current transformers shall be extended and connected to a shorting type terminal block. All six secondary leads from each set of potential transformers shall be extended and connected to a terminal block. Terminal blocks in each metering unit shall be mounted on the side wall of the unit, adjacent to the meter panel specified above. Terminal blocks shall be readily accessible from the front of the meter panel compartment in the switchgear unit.

**BGE**  
**STRATEGIC CUSTOMER ENGINEERING**

**PRIMARY CUSTOMER SUBSTATION REQUIREMENTS**  
**13.2 KV & 33 KV METAL-ENCLOSED SERVICE ENTRANCE SWITCHGEAR**

**GUIDE SPECIFICATION CSR-1**  
REVISION No. 10 – January 22, 2009

10.6.3.1. Where a remote meter cabinet is required in accordance with 10.8 below, the terminal blocks in each metering unit shall be located near the termination of the 2-inch conduit to be provided by the Customer in accordance with 10.8.3 below. Terminal blocks shall be readily accessible from the front of the metering units in the switchgear.

10.6.3.2. Terminal blocks shall be Marathon 6000DJ, Buchanan B-112, or equal approved by BGE.

10.6.4. For installations where the revenue meters are housed within the metal-enclosed switchgear cubicle the contractor shall provide a 2-inch diameter PVC conduit under the concrete pad. This conduit shall be located as close as possible to the metering terminal blocks.

10.7. Secondary wiring between the terminal blocks specified above and the revenue meter panel in the switchgear or the remote meter cabinet, will be furnished and installed by BGE.

**10.8. Remote Metering Cabinet**

10.8.1. The remote meter cabinet will be provided by BGE for installation by the Customer. Remote meter cabinets will be 36"W x 60"H x 13"D. The required quantity of the remote meter cabinets will be specified by BGE for each Customer installation. Generally, one remote meter cabinet will be required for one or two supply feeders.

10.8.2. The location of each remote meter cabinet shall be shown on the drawings and shall be readily accessible and as close as possible to the switchgear metering unit. A minimum 5-foot clearance shall be required in front of the meter cabinet. The location of the remote meter cabinet, or cabinets, shall be approved by BGE prior to installation by the Customer.

10.8.3. For installations where the revenue meters are housed in a remote meter cabinet, a 2-inch diameter conduit shall be provided by the Customer from each metering cubicle in the switchgear to this cabinet. This conduit shall be located as close as possible to the location of the metering terminal blocks. Where more than one meter cabinet is required, a 2-inch diameter conduit shall be provided between the meter cabinets. Conduits may be PVC (for underground use only), rigid, or electrical metallic tubing, as permitted by NEC for the specific customer installation. **A maximum of two 90° elbows shall be used.** Where the 2" conduit is in excess of 50' special requirements will be necessary.

10.8.4. Details of the BGE meter cabinet, termination of the conduits and grounding provisions are included in this specification.

**10.9. Telephone Connection**

10.9.1. A dedicated telephone line shall be provided by the Customer for remote revenue metering by BGE. Where a meter panel is provided in the metering unit in accordance with 9.8 above, the telephone line shall be terminated in the meter panel compartment. Where a remote meter cabinet is required in accordance with 9.9 above, the telephone line shall be

**BGE**  
**STRATEGIC CUSTOMER ENGINEERING**

**PRIMARY CUSTOMER SUBSTATION REQUIREMENTS**  
**13.2 KV & 33 KV METAL-ENCLOSED SERVICE ENTRANCE SWITCHGEAR**

**GUIDE SPECIFICATION CSR-1**

REVISION No. 10 – January 22, 2009

terminated at the remote meter cabinet.

10.9.2. The telephone line shall consist of a 4/C - two twisted pair - telephone cable in a 3/4" minimum conduit. The telephone cable shall be #24 AWG solid copper, UL type CMP, or better if required by NEC.

10.9.3. The Customer shall supply BGE with a telephone number capable of being called at any time for remote revenue metering by BGE.

**11. AUTOMATIC TRANSFER OPERATION**

**11.1. General Requirements**

11.1.1. Overcurrent lockout blocking shall be provided to prevent an automatic operation under a fault condition.

11.1.2. Current sensors or current transformers shall be provided on each phase of each incoming feeder cable.

11.1.3. Overcurrent relays or sensors shall be wired to energize a lockout relay on each incoming feeder. The lockout relay shall be wired to block the automatic transfer operation and prevent closing the other main switch, or the tie switch, into a fault.

11.1.3.1. Where separate overcurrent relays are required for blocking the automatic transfer, the relays shall provide adjustable time and instantaneous trip. Relay settings will be provided by the Customer along with supporting evidence in the form of a coordination study approved by BGE. The approved settings will be applied by the Customer and verified through current injection test by BGE in accordance with 15.3.7 below.

11.1.4. If a permanent fault occurs in the switchgear bus, the control system shall be designed to permanently block the automatic transfer operation and open the corresponding main incoming load interrupter switch after a predetermined time delay, provided that there is no voltage present on the associated incoming supply feeder. Under this condition, the automatic transfer system shall remain disabled until appropriate repairs are made and the switchgear is inspected by BGE prior to resetting the lockout relay manually and restoring the system to normal configuration.

11.1.5. If a fault occurs on an outgoing feeder, and if the fault is cleared by the outgoing feeder fuses and voltage is normal on the corresponding incoming supply feeder, the control system shall be designed to automatically reset the lockout relay after a predetermined time delay.

11.1.6. Timers shall be provided as required to allow adjustable time delay from 1 to 60 seconds to accomplish the functions described in 11.1.4 and 11.1.5 above.

**BGE**  
**STRATEGIC CUSTOMER ENGINEERING**

**PRIMARY CUSTOMER SUBSTATION REQUIREMENTS**  
**13.2 KV & 33 KV METAL-ENCLOSED SERVICE ENTRANCE SWITCHGEAR**

**GUIDE SPECIFICATION CSR-1**

REVISION No. 10 – January 22, 2009

- 11.1.7. A “MANUAL-AUTOMATIC” selector switch shall be provided for manual or automatic operation.
- 11.1.8. In the automatic position, the transfer operation shall be as described in 11.2 or 11.3 below. In the manual position, all automatic operation shall be nullified.
- 11.1.9. Manual open transition (break before make) retransfer to normal shall be possible with the selector switch in the manual position, as described in 11.2.7 or 11.3.7 below.
- 11.1.10. An electric interlock shall be provided to prevent paralleling the two incoming feeders. The interlock shall be effective with the MANUAL-AUTOMATIC selector switch in either the manual or automatic position.
- 11.1.11. A key interlock shall be provided to prevent paralleling the two incoming feeders by the manual operation of the incoming switches or the bus tie switch, after all control power is de-energized and the switches may be actuated by a removable operating handle.
- 11.1.12. A key-operated “OPEN-CLOSED” transition permissive switch shall be provided to allow BGE personnel to bypass the electrical interlock and manually parallel the two incoming feeders for closed transition (make before break) switching under controlled conditions.
- 11.1.12.1. The key-operated OPEN-CLOSED transition selector switch shall be effective with the MANUAL-AUTOMATIC selector switch in the manual position only.
- 11.1.12.2. The key shall be removable with the switch in the open transition position only and captive in the closed transition bypass position.
- 11.1.13. Under-Voltage detection for initiation of automatic transfer shall be provided on each incoming phase by one of the methods described in 11.1.14 or 11.1.15 below.
- 11.1.14. Capacitively coupled voltage devices of constant current output not requiring primary fuses.
- 11.1.14.1. Voltage devices shall consist of a high-voltage capacitor series-connected to the primary side of a dry-type transformer, completely self-contained within a non-tracking epoxy resin housing, providing full BIL capability.
- 11.1.14.2. Voltage devices shall be designed for line-to-ground connection, to provide an output voltage that is directly proportional to line-to-ground voltage.
- 11.1.14.3. Each voltage device shall be provided with a voltage limiter to prevent damage to the device’s transformer in the event the secondary circuit is inadvertently opened or the burden removed.

**BGE**  
**STRATEGIC CUSTOMER ENGINEERING**

**PRIMARY CUSTOMER SUBSTATION REQUIREMENTS**  
**13.2 KV & 33 KV METAL-ENCLOSED SERVICE ENTRANCE SWITCHGEAR**

**GUIDE SPECIFICATION CSR-1**

REVISION No. 10 – January 22, 2009

- 11.1.15. Fused potential transformers (PTs) on a drawout unit mounted in a completely isolated compartment. Full capability BIL shall be provided in both the withdrawn and closed positions.
- 11.1.15.1. The fused PT drawout unit shall be designed so that in the fully withdrawn position, the primary source side of the PT fuses shall be visible disconnected and grounded, and the PT secondary wiring visible disconnected. The frame of the drawout unit shall be grounded in all positions.
- 11.1.15.2. In both the fully withdrawn position and fully closed position, the drawout unit shall latch. The drawout unit assembly shall be designed to allow for the easy access, installation, removal, or replacement of the PTs and PT fuses with the unit in the fully withdrawn and latched position.
- 11.1.15.3. When the PT fuses are mounted horizontally, they shall not be more than 5 feet above finished floor. If mounted vertically, the top end of the PT fuses shall not be more than 6 feet above finished floor.
- 11.1.15.4. Switchgear drawings shall include details of the fused PT drawout unit showing grounding details of the PT fuses when the unit is withdrawn. Field approval by BGE or the grounding provisions is required prior to energizing the switchgear.
- 11.1.16. A timer shall be provided to allow adjustable time delay from 0 to 10 seconds between loss of voltage and initiation of automatic transfer operation.
- 11.1.17. Push-button test switches shall be provided to simulate loss of voltage on either incoming feeder for testing the automatic transfer operation.
- 11.1.18. Operational power for the motorized switches shall be provided by one of the methods described in 11.1.18.1 and 11.1.18.2 below.
- 11.1.18.1. Battery and charger system of adequate capacity.
- 11.1.18.2. Fused PTs on a drawout unit mounted in a completely isolated compartment in accordance with 11.1.15 above.
- 11.1.19. Push to test indicating lamps shall be provided as follows:
- 11.1.19.1. WHITE lamps to indicate presence of voltage on each incoming line.
- 11.1.19.2. BLUE lamp to indicate that the automatic system is “ready” for operation: (a) that all switch operators are coupled to their respective switches and are in the correct operating positions, (b) that all doors providing access to switches are closed and latched, (c) that the key operated permissive switch is in the open transition position with the key removed, (d) that the manual /automatic selector switch is in the

**BGE**  
**STRATEGIC CUSTOMER ENGINEERING**

**PRIMARY CUSTOMER SUBSTATION REQUIREMENTS**  
**13.2 KV & 33 KV METAL-ENCLOSED SERVICE ENTRANCE SWITCHGEAR**

**GUIDE SPECIFICATION CSR-1**

REVISION No. 10 – January 22, 2009

automatic position, and (e) that all control circuits are properly connected for automatic transfer.

- 11.1.19.3. AMBER lamps to indicate overcurrent blocking lockout condition on each incoming line.
- 11.1.19.4. GREEN lamps to indicate incoming switch (and tie switch, if applicable) in the open position.
- 11.1.19.5. RED lamps to indicate incoming switch (and tie switch, if applicable) in the closed position.
- 11.1.20. Complete control wiring diagram drawings for the automatic transfer system, including complete operating instructions and test procedure, shall be submitted for review and approval by BGE prior to fabrication of the switchgear.

11.1.21. In addition to the general requirements specified above, the automatic transfer system shall be provided in accordance with 11.2 or 11.3 below, as applicable for the specific service entrance switchgear arrangement.

**11.2. Two Feeder NORMAL-ALTERNATE Supply System**

**Two incoming load interrupter switches, one normally closed, and one normally open.**

- 11.2.1. The motor operated main incoming load interrupter switch on each of the incoming feeders shall operate in an automatic transfer scheme. Either incoming feeder can be selected as the normal incoming feeder or alternate incoming feeder as directed by BGE. Necessary equipment shall be installed and properly wired to accomplish the following automatic operations and control features.
- 11.2.2. Normal voltage on both incoming feeders:
  - 11.2.2.1. Main switch on normal incoming feeder closed.
  - 11.2.2.2. Main switch on alternate incoming feeder open.
- 11.2.3. Normal voltage on alternate incoming feeder and loss of voltage on the normal incoming feeder:
  - 11.2.3.1. Main switch on the incoming feeder on which there has been loss of voltage shall open after a predetermined time delay.
  - 11.2.3.2. Main switch on the other incoming feeder shall close immediately thereafter.
- 11.2.4. Loss of voltage on normal incoming feeder and voltage not normal on the alternate incoming feeder:
  - 11.2.4.1. Main switch on the incoming feeder on which there has been loss of voltage shall remain closed, and the other main switch shall not close.
  - 11.2.4.2. Should voltage become normal on the feeder to which load could have been transferred, then the transfer operation shall be in accordance with 2 above.

**BGE**  
**STRATEGIC CUSTOMER ENGINEERING**

**PRIMARY CUSTOMER SUBSTATION REQUIREMENTS**  
**13.2 KV & 33 KV METAL-ENCLOSED SERVICE ENTRANCE SWITCHGEAR**

**GUIDE SPECIFICATION CSR-1**

REVISION No. 10 – January 22, 2009

- 11.2.5. Loss and restoration of voltage on both incoming feeders simultaneously:  
11.2.5.1. Main switch on the incoming feeder supplying the load prior to loss and restoration of voltage shall not open, and main switch open shall not close.
- 11.2.6. SEEK-THE-LIVE-SOURCE FEATURE. Following restoration of normal voltage on incoming feeder from which load has been transferred and subsequent loss of voltage on the other incoming feeder:  
11.2.6.1. Main switch on the incoming feeder on which there has been a loss of voltage shall open after a predetermined time delay.  
11.2.6.2. Main switch on the incoming feeder that is available for service shall close immediately thereafter.
- 11.2.7. Following an automatic transfer operation and subsequent restoration of voltage on the incoming feeder from which the load has been transferred, retransfer to normal operation shall be done manually with the MANUAL-AUTOMATIC selector switch in the manual position. First, the main switch on the alternate incoming feeder to which load was transferred must be opened. Next, the main switch on the normal incoming feeder available now for service must be closed.
- 11.2.8. Automatic retransfer to normal shall not be permitted.
- 11.2.9. Closed transition retransfer to normal may be done manually by BGE personnel only, with the key operated OPEN-CLOSED transition permissive switch.

**11.3. Two Feeder SPLIT BUS Supply System**

**Two normally closed incoming switches and an open bus tie switch.**

- 11.3.1. The motor operated main incoming load interrupter switch on each of the incoming feeders and the motor operated bus tie load interrupter switch shall operate in an automatic transfer system. Necessary equipment shall be included and properly wired to accomplish the following automatic operations and control features.
- 11.3.2. Normal voltage on both incoming feeders:  
11.3.2.1. Both main switches closed.  
11.3.2.2. Bus tie switch open. (Recommended manually operated maintenance tie switch closed)
- 11.3.3. Normal voltage on one incoming feeder and loss of voltage on the other incoming feeder:  
11.3.3.1. Main switch on the incoming feeder on which there has been a loss of voltage shall open after a predetermined time delay.  
11.3.3.2. Bus tie switch shall close immediately thereafter.
- 11.3.4. Loss of voltage on one incoming feeder and voltage not normal on the other incoming feeder:  
11.3.4.1. Main switch on the incoming feeder on which there has been a loss of voltage shall remain closed, and the bus tie switch shall not close.

**BGE**  
**STRATEGIC CUSTOMER ENGINEERING**

**PRIMARY CUSTOMER SUBSTATION REQUIREMENTS**  
**13.2 KV & 33 KV METAL-ENCLOSED SERVICE ENTRANCE SWITCHGEAR**

**GUIDE SPECIFICATION CSR-1**

REVISION No. 10 – January 22, 2009

- 11.3.4.2. Should voltage become normal on the feeder to which load could have been transferred, then the transfer operation shall be in accordance with 2 above.
- 11.3.5. Loss and restoration of voltage on both incoming feeders simultaneously:  
11.3.5.1. Main switches on the incoming feeders shall not open, and bus tie switch shall not close.
- 11.3.6. **SEEK-THE-LIVE-SOURCE FEATURE**  
Following restoration of normal voltage on the incoming feeder from which load has been transferred, and subsequent loss of voltage on the other incoming feeder:  
11.3.6.1. Main switch on the feeder on which there has been loss of voltage shall open after a predetermined time delay.  
11.3.6.2. Main switch on the feeder that is available for service shall close immediately thereafter, while the bus tie switch remains closed.
- 11.3.7. Following an automatic transfer operation and subsequent restoration of voltage on the incoming feeder from which the load has been transferred, retransfer to normal operation shall be done manually with the MANUAL-AUTOMATIC selector switch in the manual position.
- 11.3.8. Restoration to normal is as follows: First the bus tie switch is opened. Next, close the main switch on the incoming feeder that is now available for service .
- 11.3.9. Automatic retransfer to normal shall not be permitted.
- 11.3.10. Closed transition retransfer to normal may be done manually by BGE personnel only, using the key operated OPEN-CLOSED transition permissive switch.

**12. SUBSTATION GROUNDING SYSTEM**

- 12.1. A driven ground rod system consisting of copper clad steel or stainless steel ground rods shall be installed by the Customer in the substation area. The ground rods shall be interconnected with minimum 4/0 AWG bare stranded copper or copper clad wire to form a grid system.
- 12.2. The substation grounding system shall be tested by industry accepted methods in accordance with 14.2 below. The measured ground resistance shall not exceed 5 ohm.
- 12.3. All non-current carrying metal parts and equipment in the substation area shall be connected to the grounding system.
- 12.4. The switchgear ground bus shall be connected to the substation grounding system at a minimum of two places with minimum 4/0 AWG bare stranded copper wire, in accordance with 12.6 below.

**BGE**  
**STRATEGIC CUSTOMER ENGINEERING**

**PRIMARY CUSTOMER SUBSTATION REQUIREMENTS**  
**13.2 KV & 33 KV METAL-ENCLOSED SERVICE ENTRANCE SWITCHGEAR**

**GUIDE SPECIFICATION CSR-1**  
**REVISION No. 10 – January 22, 2009**

- 12.5. Exothermic joints shall be used for all connections below grade. Double-bolted 3/8” or single bolted 1/2” compression type connectors shall be used for **all** above ground connections to substation equipment.
- 12.6. Where metal pipe guards or barriers are required for vehicular traffic protection in the substation area, in accordance with 4.2.15 above, they shall be connected to the grounding system.
- 12.7. Where a substation fence is provided by the Customer in accordance with 4.2.10 above, the fence shall be connected to the substation grounding system.
- 12.7.1. As a minimum, every other fence post shall be connected to the grounding system with a minimum 1/0 AWG bare stranded copper or copper clad wire located 2’-6” outside the substation fence, and buried 12” below grade.
- 12.7.2. The substation fence gates shall be equipped with a flexible braided ground strap at the hinged end.
- 12.8. Typical substation ground grid details are included in this specification (See Figure 8).
- 12.9. **REQUIRED SUBMITAL:** A drawing detailing these grounding requirements is required to be submitted to BGE for review and approval

**13. TRANSFORMER**

13.1. Three-phase transformer shall have the following ratings:

	<b><u>13,200V</u></b>	<b><u>33,000V</u></b>
	<b><u>Service</u></b>	<b><u>Service</u></b>
Rated primary voltage, V, rms	13,200	33,000
Rated secondary voltage, V, rms	(*)	(*)
Insulation levels, rated withstand voltage:		
Impulse (BIL), kV, crest, not less than	95	150
Rated frequency, hertz	60	60
Minimum Impedance on Transformer base	4 %	5 %

(\*) As required by the Customer’s secondary system.

- 13.2. Transformer shall be equipped with full capacity, manual control, primary taps for de-energized operation. Two 2.5% taps above and two 2.5% taps below the rated primary voltage shall be provided.
- 13.3. Transformer windings may be connected DELTA-WYE or WYE-WYE.
- 13.4. Depending on the specific location of the Customer substation, the BGE supply system may be one of the following:

**BGE**  
**STRATEGIC CUSTOMER ENGINEERING**

**PRIMARY CUSTOMER SUBSTATION REQUIREMENTS**  
**13.2 KV & 33 KV METAL-ENCLOSED SERVICE ENTRANCE SWITCHGEAR**

**GUIDE SPECIFICATION CSR-1**  
REVISION No. 10 – January 22, 2009

- 13.4.1. 13,200 volt, 3-phase, 4-wire, 60 hertz, WYE system with the neutral solidly grounded at multiple locations, including the Customer facility.
- 13.4.2. 33,000 volt, 3-phase, 4-wire, 60 hertz, WYE system with the neutral solidly grounded at multiple locations, including the Customer facility.
- 13.5. Transformers shall be built in accordance with the latest applicable industry standard for the specific class of apparatus.
- 13.6. A transformer nameplate shall be provided in accordance with the latest ANSI standard showing all pertinent information, including a connection diagram and vector diagram showing all windings, taps, removable links, terminals, etc., kVA, insulation and temperature rise class, BIL ratings, voltage ratio taps, and impedance.
- 13.7. **REQUIRED SUBMITAL**: A drawing detailing these transformer requirements is required to be submitted to BGE for review and approval.

**14. SHORT-CIRCUIT AND COORDINATION STUDY**

- 14.1. **REQUIRED SUBMITAL**: A coordination study is required to be submitted to BGE for review and approval
- 14.2. A short-circuit and coordination study shall be prepared by the Customer. The study shall include a system one line diagram and impedance one line diagram. The study shall include the proposed ampere rating and time-current characteristic of the power or electronic fuses. Where a fixed mounted circuit breaker is furnished, the study shall include the proposed protective relay characteristic and settings.
- 14.3. The study shall include coordination curves showing the specific time-current characteristics of each protective device plotted in such manner that all upstream devices, including BGE protective devices (where applicable), will be clearly depicted on a single sheet.
- 14.4. Available short-circuit currents or impedances of the BGE system supplying the Customer, and time-current characteristics and settings of the BGE protective devices on the supply feeders shall be requested from BGE prior to preparing the study.
- 14.5. Proposed time-current characteristics and ampere ratings of the power or electronic fuses and, if applicable, the protective relay time-current characteristics and settings of the fixed mounted circuit breakers in the service entrance switchgear are subject to BGE approval. Copy of the study shall be submitted to BGE for approval prior to fabrication of the switchgear.

**15. INSPECTION AND TESTS PRIOR TO ENERGIZING CUSTOMER OWNED SUBSTATION**

- 15.1. **REQUIRED SUBMITAL**: Certificate of Electrical Inspection

**BGE**  
**STRATEGIC CUSTOMER ENGINEERING**

**PRIMARY CUSTOMER SUBSTATION REQUIREMENTS**  
**13.2 KV & 33 KV METAL-ENCLOSED SERVICE ENTRANCE SWITCHGEAR**

**GUIDE SPECIFICATION CSR-1**

REVISION No. 10 – January 22, 2009

- 15.1.1. A certificate of electrical inspection covering all new service entrance equipment, or reconnection of modified or relocated existing service entrance equipment, shall be obtained by the Customer from the local inspection authority having jurisdiction. A copy of the inspection certificate shall be forwarded to BGE before such equipment may be energized by BGE.
- 15.1.2. On State or Federal government projects, where the local inspection authority would have no jurisdiction, a “Letter of Exemption” covering approval of the installation will be acceptable in lieu of the inspection certificate. The letter shall be signed by an agent authorized by the State of Maryland – Fire Marshal and forwarded to BGE before the service entrance equipment may be energized by BGE. A copy of the letter and list of authorized agents will be provided upon request.

**15.2. Field Inspection and Tests to be Provided by the Customer**

- 15.2.1. Field tests to be provided by the Customer shall be performed by a qualified testing company, such as a certified International Electrical Testing Association (NETA) member, and meet the NETA Maintenance Testing Specifications for Electrical Power Distribution Equipment and Systems. NICET and AVO certifications are acceptable.
- 15.2.2. A written report of the field tests shall be forwarded to BGE to demonstrate compliance with this requirement before the service entrance equipment may be energized by BGE.
- 15.2.3. The measured ground resistance of the substation grounding system, in accordance with Section 11 above, shall not exceed five ohms. Record of the measured ground resistance shall be included in the written report to be forwarded to BGE.
- 15.2.4. High potential tests of the service entrance equipment shall be made by the Customer’s testing company as near as possible to the scheduled service date.  
**NOTE:** This test is only valid for a period of 30 days. It will be necessary to re-test the switchgear if more than 30 days elapse between the date of the high potential tests and the date for energizing the switchgear.
- 15.2.5. Where automatic transfer is provided, and overcurrent-blocking relays are installed, settings will be provided by the Customer in accordance with 11.1.3 above.
- 15.2.6. It shall be the Customer responsibility to test the automatic transfer system to assure satisfactory operation. BGE personnel will witness the test in accordance with 15.3.8 below.
- 15.2.7. It is the Customer responsibility to inspect and test the entire Customer owned substation installation prior to energizing, and periodically thereafter.
- 15.2.8. **REQUIRED SUBMITTAL:** A “Certified Test Report” shall be submitted to BGE for review and approval. A BGE approval of the results of this test must be given prior to arranging for the cut-in of the equipment.

**BGE**  
**STRATEGIC CUSTOMER ENGINEERING**

**PRIMARY CUSTOMER SUBSTATION REQUIREMENTS**  
**13.2 KV & 33 KV METAL-ENCLOSED SERVICE ENTRANCE SWITCHGEAR**

**GUIDE SPECIFICATION CSR-1**  
REVISION No. 10 – January 22, 2009

**15.3. Inspection and Tests to be Provided by BGE.**

- 15.3.1. Prior to energizing the Customer owned substation, BGE will perform an initial inspection of the Customer's service entrance equipment. This inspection is to safeguard the public and assure a safe working environment for BGE. The BGE inspection is not intended to be a complete Customer installation check.
- 15.3.2. If for any reason the Customer's high voltage service entrance equipment is not installed in a manner acceptable to BGE and in accordance with good engineering practices and applicable laws, regulations and codes, and this specifications, then following such initial inspection and before energizing the equipment for permanent use, the Customer shall make such modifications or repairs as BGE may require. The Customer shall notify BGE when the required modifications are completed.
- 15.3.3. In Customer substations where two or more incoming supply feeders are installed, BGE will make live high voltage phase-out tests between the incoming feeders.
- 15.3.4. In Customer substations where the incoming load interrupter switches are equipped with automatic transfer facilities, BGE will perform the following functions (if applicable):
- 15.3.5. BGE will wire check the control wiring from the overcurrent blocking current transformers or current sensors to the protective overcurrent blocking relays. Final "as-built" control wiring diagram drawings shall be furnished to BGE for review and approval before BGE can perform the wire check. BGE will not energize the Customer substation until the "as-built" drawings are furnished by the Customer.
- 15.3.6. BGE will bring to the attention of the Customer any problems found in the protective overcurrent blocking and lock-out relaying control wiring for correction by the Customer. After the Customer has corrected the required wiring problems, BGE will complete the wire check.
- 15.3.7. BGE will verify the overcurrent blocking relay settings, if applicable, through secondary current injection test.
- 15.3.8. BGE will witness the test of the automatic transfer system (to be performed by the Customer) in accordance with 15.2.6 above, to verify the satisfactory operation of the automatic transfer system and overcurrent protective blocking feature.

**16. REQUIRED SUBMITTALS:**

- 16.1. The following is a summary of the documents requiring approval by BGE as indicated in this specification:
  - 16.1.1. Preliminary drawings and specifications covering the primary Customer substation. This shall include the service entrance switchgear equipment installation, incoming cable

**BGE**  
**STRATEGIC CUSTOMER ENGINEERING**

**PRIMARY CUSTOMER SUBSTATION REQUIREMENTS**  
**13.2 KV & 33 KV METAL-ENCLOSED SERVICE ENTRANCE SWITCHGEAR**

**GUIDE SPECIFICATION CSR-1**

REVISION No. 10 – January 22, 2009

conduits, telephone circuit for remote BGE metering, substation transformers, and grounding facilities.

- 16.1.2. Manufacturer's shop drawings for the entire service entrance switchgear assembly, including but not limited to, load interrupter switches and protective fuse equipment or fixed mounted circuit breakers, grounding details of drawout fuse units, BGE metering units and grounding devices, and schematic and control wiring diagram drawings where applicable.
- 16.1.3. Short-circuit and coordination study.
- 16.1.4. Manufacturer's "as-built" shop drawings for the entire service entrance switchgear assembly, including but not limited to, schematic and control wiring diagrams.
- 16.1.5. Certified test report of the applicable inspections and tests to be performed by the Customer prior to energizing the service entrance switchgear.
- 16.1.6. Certificate of Inspection by the proper Code enforcing inspection authority, or a letter covering approval by the duly federal or state government agent.

**17. SCHEDULING & OUTAGE REQUESTS**

The following represents the most typical sequence of events for scheduling the document approvals, outage requests, and cut-in of equipment.

**Please note:** It takes a minimum of 10 working days to schedule outages.

**17.1. Document Approvals:**

- 17.1.1. Submit one-line and grounding drawings for approval (2 to 6 weeks turn around)
- 17.1.2. Submit equipment specification for approval (2 to 6 weeks turn around)
- 17.1.3. Submit coordination study for approval (2 to 6 weeks turn around)
- 17.1.4. Submit Manufacturer's shop drawings for approval (2 to 6 weeks turn around)

**17.2. Cut-in Procedures:**

- 17.2.1. Customer to arrange for independent testing of the substation equipment
- 17.2.2. Customer to submit Certified Test Report for approval
- 17.2.3. Customer to arrange for electrical inspector to issue a "Certificate of Electrical Inspection" to BGE authorizing the energization of the substation equipment
- 17.2.4. **Customer to call responsible engineer to arrange for a precut-in meeting (minimum thirty days prior to cut-in)**
- 17.2.5. During the precut-in meeting a service date will be established
- 17.2.6. **NOTE: a minimum of 10 work days are required to arrange for outages necessary to cut-in new equipment**

**17.3. Outage Requests:**

- 17.3.1. BGE Senior Key Account Engineers are responsible for obtaining outages at all primary service Customer substations. If you know who that person is you may call them direct. Otherwise the general number is 410-265-4086. This person will put you in touch with the

**BGE**  
**STRATEGIC CUSTOMER ENGINEERING**

**PRIMARY CUSTOMER SUBSTATION REQUIREMENTS**  
**13.2 KV & 33 KV METAL-ENCLOSED SERVICE ENTRANCE SWITCHGEAR**

**GUIDE SPECIFICATION CSR-1**

REVISION No. 10 – January 22, 2009

Customer rep or handle the outage request directly.

**18. TYPICAL SWITCHGEAR ARRANGEMENTS AND DETAILS**

18.1. The following figures represent various typical arrangements of metal-enclosed service entrance switchgear, BGE metering arrangements, and grounding details.

- 18.1.1. Figure 1 – Single Supply Feeder
- 18.1.2. Figure 2 – Two Supply Feeders – Normal & Alternate Supply
- 18.1.3. Figure 3 – Two Supply Feeders – Split-Bus Supply
- 18.1.4. Figure 4 – BGE Metering Units
- 18.1.5. Figure 5 – Grounding Devices
- 18.1.6. Figure 6 – BGE Meter Cabinet
- 18.1.7. Figure 7 – Incoming Switch Unit and BGE Surge Arresters Details
- 18.1.8. Figure 8 – Substation Grounding Details
- 18.1.9. Figure 9 – Substation Fence Grounding Details

18.2. Specific Customer installations may require modifications to these typical arrangements. Any modifications shall be reviewed and approved by BGE in writing prior to finalizing the design.

**BGE**  
**STRATEGIC CUSTOMER ENGINEERING**

**PRIMARY CUSTOMER SUBSTATION REQUIREMENTS**  
**13.2 KV & 33 KV METAL-ENCLOSED SERVICE ENTRANCE SWITCHGEAR**

**GUIDE SPECIFICATION CSR-1**

REVISION No. 10 – January 22, 2009

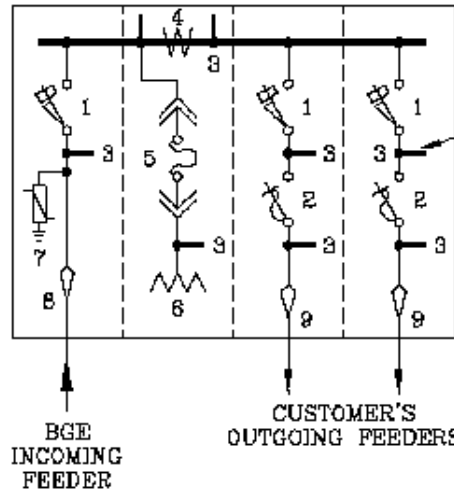

**NOTE:**

ADDITIONAL GROUND BAILS ON 33kV SWITCHGEAR ONLY.

(SEE PAGE 30, FIGURE 3, FOR LEGEND.)

**SINGLE BGE FEEDER**  
**FIGURE NO.1**

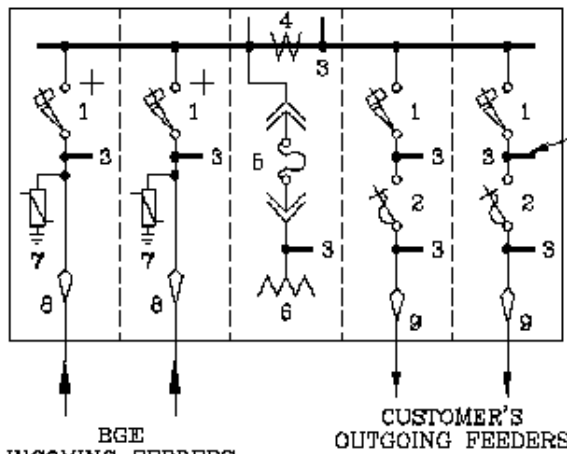

**NOTE:**

ADDITIONAL GROUND BAILS ON 33kV SWITCHGEAR ONLY.

(SEE PAGE 30, FIGURE 3, FOR LEGEND.)

BGE  
INCOMING FEEDERS  
(NORMAL & ALTERNATE SUPPLY)

+ KEY INTERLOCKS TO PREVENT PARALLELING SUPPLY FEEDERS.

TYPICAL ARRANGEMENT ALSO APPLICABLE TO POWER OPERATED SWITCHES EQUIPPED WITH AUTOMATIC TRANSFER OPERATION.

**TWO BGE FEEDERS – SINGLE BUS SWGR.**  
**FIGURE NO.2**

# BGE STRATEGIC CUSTOMER ENGINEERING

## PRIMARY CUSTOMER SUBSTATION REQUIREMENTS 13.2 KV & 33 KV METAL-ENCLOSED SERVICE ENTRANCE SWITCHGEAR

### GUIDE SPECIFICATION CSR-1

REVISION No. 10 – January 22, 2009

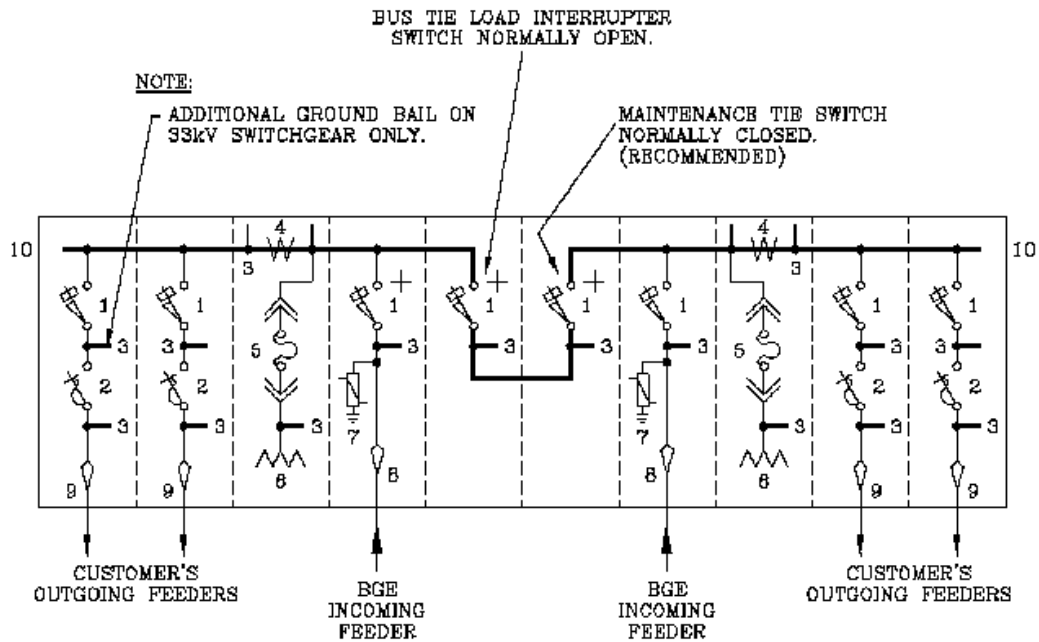

+ KEY INTERLOCKS TO PREVENT PARALLELING SUPPLY FEEDERS.  
TYPICAL ARRANGEMENT ALSO APPLICABLE TO POWER OPERATED SWITCHES EQUIPPED  
WITH AUTOMATIC TRANSFER OPERATION.

NOTE: SPLIT BUS SUPPLY MAY BE REQUIRED BY BGE BASED ON LOAD MAGNITUDE  
AND LOCATION.

### LEGEND

- |  |   |
|--|---|
| 1. LOAD INTERRUPTER SWITCH             | 6. BGE FUSES                                      |
| 2. POWER FUSES                         | 7. BGE SURGE ARRESTERS                            |
| 3. GROUNDING BAILES                    | 8. BGE CABLE TERMINATIONS                         |
| 4. BGE METERING CURRENT TRANSFORMERS   | 9. CABLE TERMINATIONS                             |
| 5. BGE METERING POTENTIAL TRANSFORMERS | 10. PROVISIONS FOR FUTURE<br>SWITCHGEAR EXTENSION |

TWO BGE FEEDERS – SPLIT BUS SWGR.  
FIGURE NO.3

**BGE**  
**STRATEGIC CUSTOMER ENGINEERING**

**PRIMARY CUSTOMER SUBSTATION REQUIREMENTS**  
**13.2 KV & 33 KV METAL-ENCLOSED SERVICE ENTRANCE SWITCHGEAR**

**GUIDE SPECIFICATION CSR-1**

REVISION No. 10 – January 22, 2009

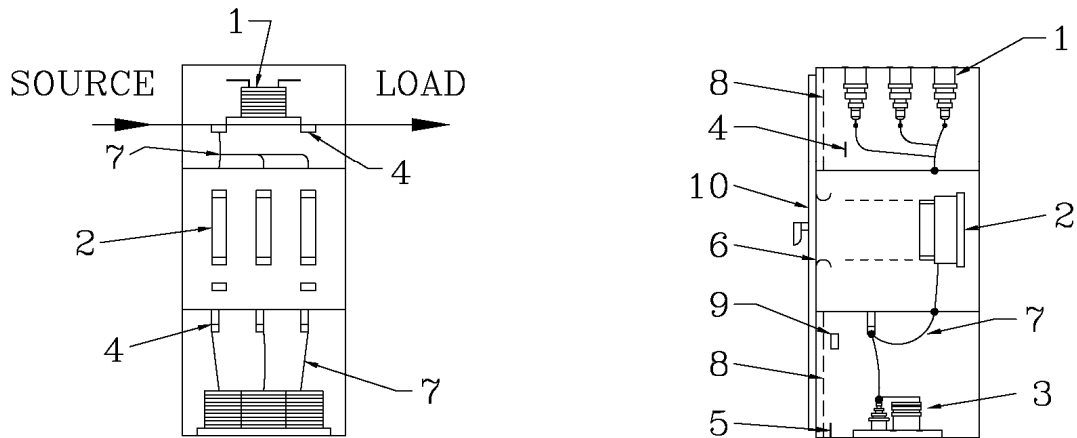

FRONT VIEW

SIDE VIEW

TYPICAL ARRANGEMENT FOR 13.2 and 33 kV METERING UNIT

NOTE: TYPICAL ARRANGEMENT SHOWN DOES NOT PRECLUDE OTHERS, PROVIDED  
BGE APPROVAL IS GIVEN PRIOR TO SWITCHGEAR FABRICATION.

LEGEND

- |                                  |  |
|----------------------------------|--|
| 1. BGE CURRENT TRANSFORMERS      | 6. GROUNDING FINGERS (P.T. FUSES)                |
| 2. BGE POTENTIAL TRANSF. FUSES   | 7. CUSTOMER WIRING                               |
| 3. BGE POTENTIAL TRANSFORMERS    | 8. HINGED SCREEN BARRIER                         |
| 4. GROUNDING BAILS (C.T. & P.T.) | 9. TERMINAL BLOCK & CUSTOMER<br>SECONDARY WIRING |
| 5. GROUNDING BAIL (GROUND BUS)   | 10. PADLOCKABLE DOOR                             |

BGE METERING UNITS

FIGURE NO.4

**BGE**  
**STRATEGIC CUSTOMER ENGINEERING**

**PRIMARY CUSTOMER SUBSTATION REQUIREMENTS**  
**13.2 KV & 33 KV METAL-ENCLOSED SERVICE ENTRANCE SWITCHGEAR**

**GUIDE SPECIFICATION CSR-1**

REVISION No. 10 – January 22, 2009

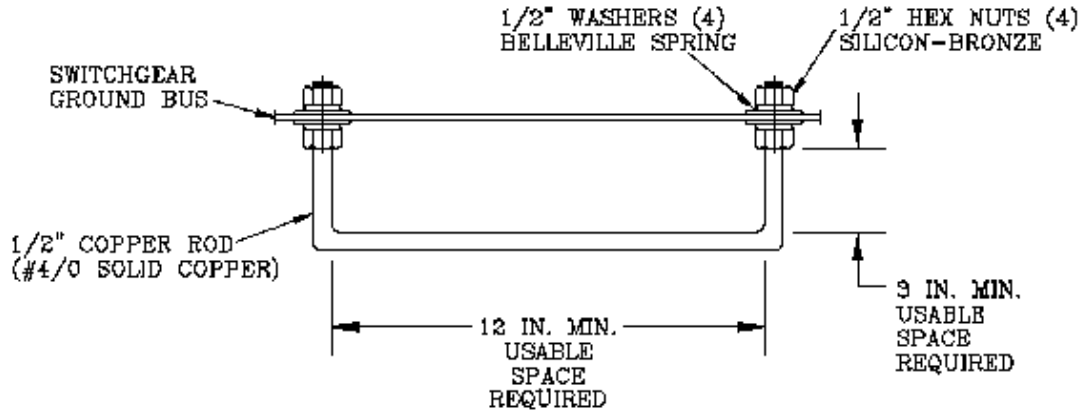

**SWITCHGEAR GROUND BUS**

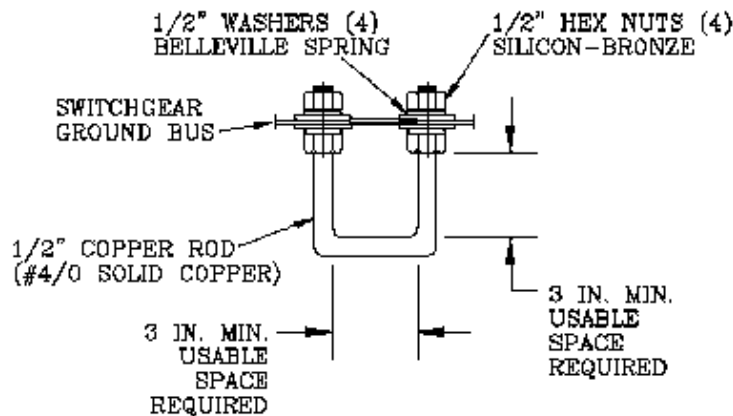

**CURRENT, POTENTIAL TRANSF., INCOMING LOAD INTERRUPTER SW., & OUTGOING FEEDER FUSES**

ALTERNATE DESIGNS MAY BE CONSIDERED BY BGE PROVIDED THEY ARE APPROVED BY BGE PRIOR TO FABRICATION OF SWITCHGEAR AND THEY ARE CERTIFIED BY TEST TO WITHSTAND MOMENTARY RMS ASYMMETRICAL FAULT CURRENT RATING OF THE SWITCHGEAR.

**GROUNDING DEVICES**  
**FIGURE NO.5**



**BGE**  
**STRATEGIC CUSTOMER ENGINEERING**

**PRIMARY CUSTOMER SUBSTATION REQUIREMENTS**  
**13.2 KV & 33 KV METAL-ENCLOSED SERVICE ENTRANCE SWITCHGEAR**

**GUIDE SPECIFICATION CSR-1**

REVISION No. 10 – January 22, 2009

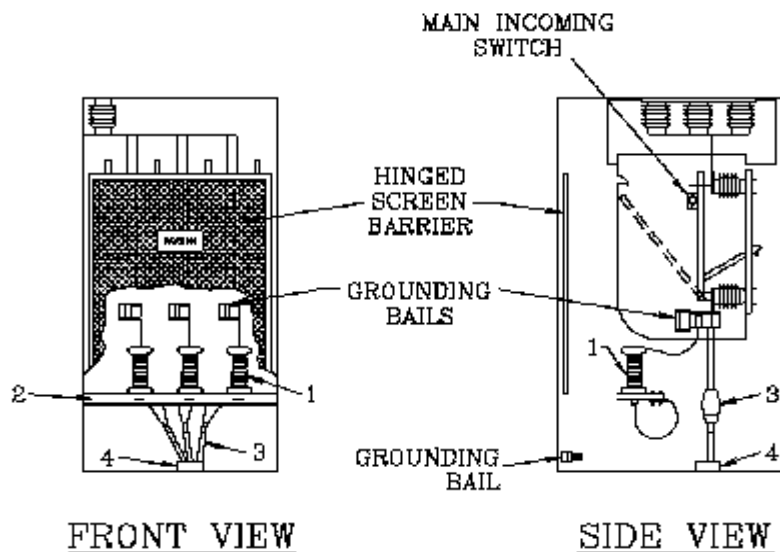

**LEGEND**

1. DISTRIBUTION CLASS METAL-OXIDE SURGE ARRESTERS BY BGE.
2. REMOVABLE MOUNTING BRACKET BY CUSTOMER.
3. INCOMING CABLE TERMINATION BY BGE.
4. 6 IN. DIAMETER RIGID NON-METALLIC CONDUIT BY CUSTOMER.

**INCOMING LOAD INTERRUPTER SWITCH UNIT**  
**AND BGE SURGE ARRESTER DETAILS**  
**FIGURE NO.7**

**BGE**  
**STRATEGIC CUSTOMER ENGINEERING**

**PRIMARY CUSTOMER SUBSTATION REQUIREMENTS**  
**13.2 KV & 33 KV METAL-ENCLOSED SERVICE ENTRANCE SWITCHGEAR**

**GUIDE SPECIFICATION CSR-1**

REVISION No. 10 – January 22, 2009

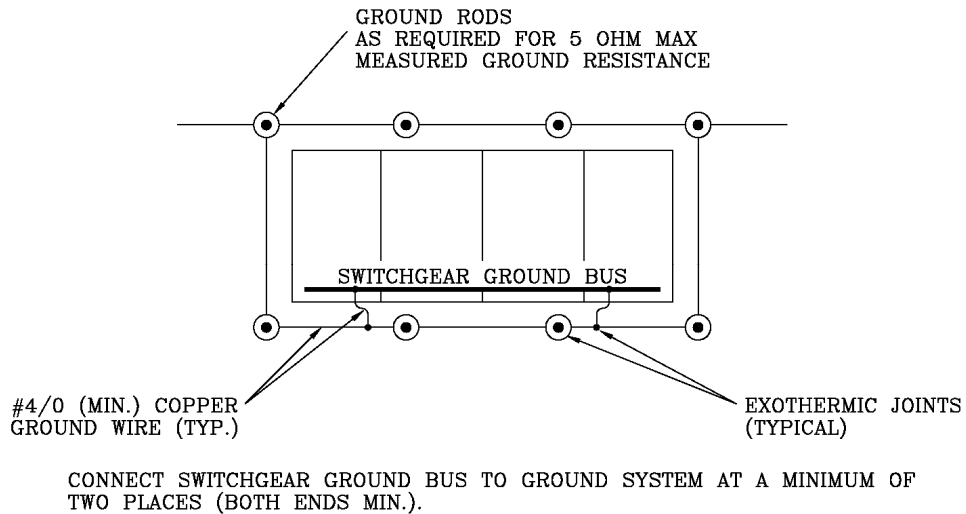

SWITCHGEAR GROUNDING

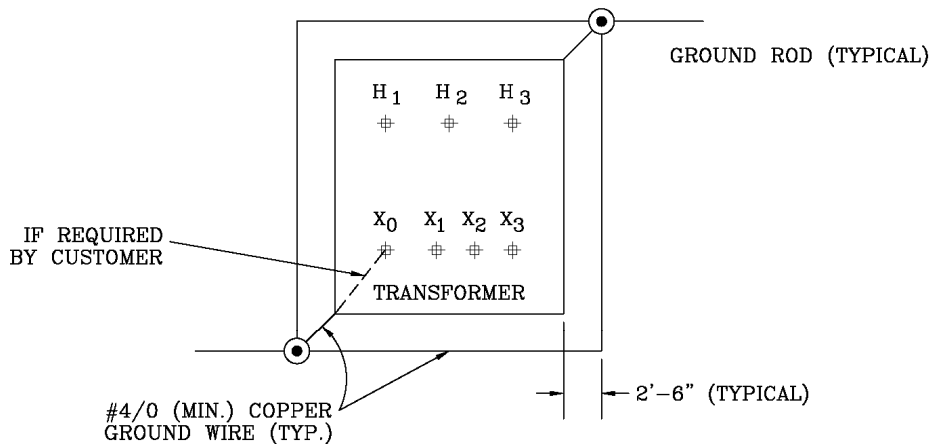

TRANSFORMER GROUNDING

FIGURE NO.8

**BGE**  
**STRATEGIC CUSTOMER ENGINEERING**

**PRIMARY CUSTOMER SUBSTATION REQUIREMENTS**  
**13.2 KV & 33 KV METAL-ENCLOSED SERVICE ENTRANCE SWITCHGEAR**

**GUIDE SPECIFICATION CSR-1**

REVISION No. 10 – January 22, 2009

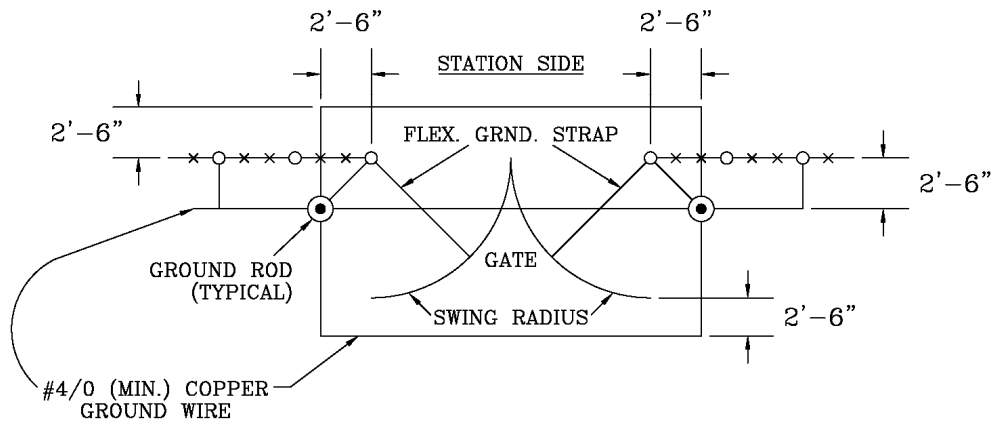
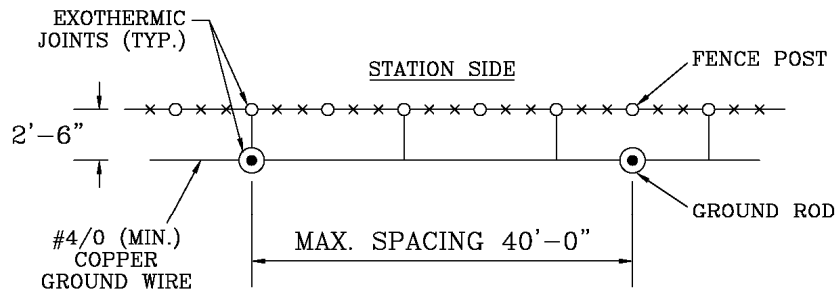

**FENCE & GATE GROUNDING (IF APPLICABLE)**  
**SUBSTATION GROUNDING DETAILS**  
**FIGURE NO.8**