

BGE
STRATEGIC CUSTOMER ENGINEERING

PRIMARY CUSTOMER SUBSTATION REQUIREMENTS
13.2 KV METAL-CLAD SERVICE ENTRANCE SWITCHGEAR
FOR USE ON THE AREA NETWORK SYSTEM

GUIDE SPECIFICATION CSR-4

REVISION No. 1 – January, 2005

TABLE OF CONTENTS

1. GENERAL	2
2. BGE SUPPLY FEEDER	4
3. SWITCHGEAR ENCLOSURE AND ASSEMBLY	5
4. CIRCUIT BREAKER	9
5. SWITCHGEAR EQUIPMENT	10
6. MAIN AND GROUND BUS	15
7. GROUND AND TEST DEVICE	17
8. SWITCHGEAR CONTROL WIRING	19
9. BGE REVENUE METERING UNIT	20
10. SUBSTATION GROUNDING SYSTEM	26
11. TRANSFORMER	27
12. SECONDARY NETWORK PROTECTORS	28
13. SHORT-CIRCUIT AND COORDINATION STUDY	29
14. INSPECTIONS AND TESTS	30
15. REQUIRED SUBMITTALS	32
16. SCHEDULING & OUTAGES	33
17. TYPICAL ARRANGEMENTS AND DETAILS	34

BGE
STRATEGIC CUSTOMER ENGINEERING

PRIMARY CUSTOMER SUBSTATION REQUIREMENTS
13.2 KV METAL-CLAD SERVICE ENTRANCE SWITCHGEAR
FOR USE ON THE AREA NETWORK SYSTEM

GUIDE SPECIFICATION CSR-4

REVISION No. 1 – January, 2005

1. GENERAL

- 1.1. This Guide Specification describes the requirements for the design and installation of **METAL-CLAD SWITCHGEAR** used as 13.2 kV primary service entrance equipment by Customers on the BGE **NETWORK SUPPLY SYSTEM**.
- 1.2. Please take note of the required submittals throughout this specification.
- 1.3. The supply voltage at each specific Customer substation shall be determine by BGE, depending on the Customer load requirements and available supply feeder or feeders at the Customer substation location. The Customer shall consult BGE for specific supply voltage requirements prior to proceeding.
- 1.4. These specifications cover the minimum BGE requirements. Specific installations may require modifications to these specifications. The Customer may elect to provide a greater level of protection. Requests for exceptions to BGE requirements shall be made in writing, clearly indicating the specific requirement and the proposed alternative. BGE will respond in writing to the requested exception.
- 1.5. The equipment shall meet all applicable requirements of ANSI, OSHA, IEEE, NEMA, National Electrical Code (NEC), National Electrical Safety Code (NESC), local codes, and BGE. Where applicable, the equipment shall be Underwriters Laboratories (UL) listed. The requirements of BGE are in addition to and in no way a waiver of the applicable standards and codes.
- 1.6. **REQUIRED SUBMITTAL**: Contract drawings and specifications covering the Customer substation installation, including the service entrance switchgear shall be submitted to BGE for review and approval prior to their release for contractual bidding. Drawings submitted to BGE shall include one-line diagram, plan details of the switchgear installation, and grounding system.
- 1.7. **REQUIRED SUBMITTAL**: Manufacturer shop drawings for the entire service entrance switchgear assembly shall be submitted to BGE for review and approval prior to fabrication of the switchgear. This review and approval may take up to six weeks and could affect the in-service date if shop drawings are not submitted to BGE in a timely manner for proper and comprehensive review by BGE. BGE will review partial or preliminary design drawings as a courtesy, but final drawings are required for BGE's approval.

BGE
STRATEGIC CUSTOMER ENGINEERING

PRIMARY CUSTOMER SUBSTATION REQUIREMENTS
13.2 KV METAL-CLAD SERVICE ENTRANCE SWITCHGEAR
FOR USE ON THE AREA NETWORK SYSTEM

GUIDE SPECIFICATION CSR-4

REVISION No. 1 – January, 2005

- 1.8. **REQUIRED SUBMITTAL:** A short-circuit and coordination study shall be prepared by the Customer and submitted to BGE for review and approval. The coordination study shall indicate the ampere rating and time-current characteristics of the proposed power or electronic fuses on the outgoing feeders, or settings of the overcurrent relays on fixed mounted circuit breakers on the outgoing feeders, if applicable, which are subject to BGE approval. Available short-circuit current at the Customer primary service entrance equipment and BGE supply feeder overcurrent relay settings will be furnished by BGE upon request by the Customer.
- 1.9. Where parallel operation of Customer owned generation equipment is being considered the Customer shall contact BGE at the onset of planning. BGE has separate Customer generation requirements for paralleling operation with the BGE system. Parallel operation of Customer owned generation with the BGE system, regardless of the voltage application, is subject to approval by BGE.
- 1.10. The connection of Customer equipment to the BGE system shall not reduce the quality of service to other Customers. No abnormal voltages, frequencies, harmonics, or service interruptions will be permitted.
- 1.11. BGE primary supply feeders shall not be paralleled by the Customer at any time.
- 1.12. Arrangements shall be made for ready access to the Customer substation and BGE revenue metering equipment by BGE personnel whenever it is required in performance of their duties. An "Access Notification" form must be completed by the Customer.
- 1.13. The Customer shall provide master-keyed padlocks for the substation access door, all load interrupter switch operating handles and the doors of all switchgear units, except the BGE metering unit door - the locks for this door will be provided by BGE. One key shall be located in a padlockable metal keybox. The keybox shall have a hinged cover with suitable provisions for padlocking by BGE. The keybox will be provided by BGE and mounted by the Customer outside the substation, adjacent to the access door.
- 1.14. All of the Customer load, including station service load, must be connected on the load side of the revenue metering. Where required for operation of an automatic transfer system, incoming voltage sensing potential devices or fused potential transformers will be permitted on the line side of the revenue metering, provided their installation meets applicable BGE requirements included in this specification.

BGE
STRATEGIC CUSTOMER ENGINEERING

PRIMARY CUSTOMER SUBSTATION REQUIREMENTS
13.2 KV METAL-CLAD SERVICE ENTRANCE SWITCHGEAR
FOR USE ON THE AREA NETWORK SYSTEM

GUIDE SPECIFICATION CSR-4

REVISION No. 1 – January, 2005

- 1.15. A telephone line for remote revenue meter reading by BGE shall be provided by the Customer in accordance with this specification. In addition to the telephone line required for remote revenue metering, it is strongly recommended that the Customer substation be equipped with a telephone to facilitate communication during start-up, switching, or emergencies.
- 1.16. One-line wiring diagrams of typical metal-enclosed primary service entrance switchgear arrangements are included in these specifications.
- 1.17. A listing of Manufacturers of metal-enclosed switchgear currently approved by BGE is available upon request.

2. BGE SUPPLY FEEDER

- 2.1. The service connection between the proposed Customer substation and the BGE supply feeder or feeders shall be installed in accordance with BGE Electric Service Rules and Regulations, and the Maryland Public Service Commission.
- 2.2. **REQUIRED SUBMITTAL:** All conduit, duct banks, pull boxes, manholes, supports, etc., which may be required to carry the incoming primary voltage supply feeders from the point where they enter the Customer property to the point at which they terminate in the incoming unit of the Customer service entrance switchgear, shall be furnished and installed by the Customer subject to BGE approval.
- 2.3. Where applicable, BGE will direct bury the service cables within the Customer property or in public space. If direct buried conduits or concrete encased duct banks are required by the Customer or by the local jurisdiction outside the Customer property, the Customer shall install the necessary conduit or duct bank subject to BGE approval. BGE will install the service cables in the conduits provided by the Customer and pull the cables into the service entrance switchgear incoming unit.
- 2.4. Minimum conduit size shall be six-inch diameter. Five-inch diameter conduit may be acceptable for 13.2 kV supply at some locations, subject to BGE approval. No more than the equivalent of two 90 degree bends will be permitted in any conduit run. Fabricated 90-degree elbows to terminate the conduits in the Customer incoming unit shall have a minimum bending radius of 48", unless otherwise approved by BGE.

BGE
STRATEGIC CUSTOMER ENGINEERING

PRIMARY CUSTOMER SUBSTATION REQUIREMENTS
13.2 KV METAL-CLAD SERVICE ENTRANCE SWITCHGEAR
FOR USE ON THE AREA NETWORK SYSTEM

GUIDE SPECIFICATION CSR-4

REVISION No. 1 – January, 2005

- 2.5. The preferred conduit material is non-metallic PVC. Metallic conduit may be acceptable at some locations, subject to BGE approval. PVC conduit inserts may be required by BGE in metallic conduits, depending on the size of the service cables and the length of the supply cable pull.
- 2.6. The incoming supply feeders may enter the switchgear incoming unit from either the top or the bottom, depending upon the Customer requirements. Top cable entry will require switchgear modifications or installation of a cable trough below the switchgear unit with top entry.
- 2.6.1. Where the incoming supply feeders enter from the bottom, two incoming conduits, one active and one spare, shall be provided by the Customer in the incoming unit. Where parallel supply feeder cables are required, four conduits shall be provided, two active and two spare.
- 2.6.2. Where the incoming supply feeders enter from the top, the conduit installation shall meet the approval of the local electrical inspection authority having jurisdiction. One spare conduit shall be provided for each active conduit. Use of an 11 gauge steel pull box may negate the need for the second conduit to the switchgear for top entry applications.
- 2.7. The Baltimore Gas and Electric Company will determine the number of 13.2 kV network feeders required to supply each particular customer installation (Schedule P) located within the territory supplied from the Baltimore Gas and Electric Company's 13.2 kV network feeder system.
- 2.8. For each Baltimore Gas and Electric Company network feeder required to supply the particular installation, the customer shall provide an assembly of three units for 15 kV metal-clad switchgear as shown on the attached drawing and as specified below.

3. SWITCHGEAR ENCLOSURE AND ASSEMBLY

- 3.1. The switchgear assembly shall consist of free-standing, self-supporting unit containing but not limited to such devices as power circuit breakers, ground and test devices, revenue metering equipment, current transformers for overcurrent protection, fused potential transformers, and fused control power transformers, as may apply to the specific Customer substation. Where applicable, provisions shall be made for extension

BGE
STRATEGIC CUSTOMER ENGINEERING

PRIMARY CUSTOMER SUBSTATION REQUIREMENTS
13.2 KV METAL-CLAD SERVICE ENTRANCE SWITCHGEAR
FOR USE ON THE AREA NETWORK SYSTEM

GUIDE SPECIFICATION CSR-4

REVISION No. 1 – January, 2005

to future switchgear units.

- 3.2. The switchgear enclosure shall have a rigid self-supporting structural steel framework. All framework shall be covered with not less than 11 gauge sheet steel, free from cracks, dent, seams, and other defects. The sheet steel covering the exterior of individual units shall be designed to insure complete isolation between adjacent switchgear units. All equipment requiring inspection or servicing shall be accessible by means of interior doors or plates to access inter-connecting bus.
- 3.3. Each switchgear unit shall be provided with front doors. Doors shall also be provided where access to the rear of the BGE metering unit is required. Where a two-high breaker arrangement is furnished, two half sized doors, one for each breaker compartment, may be provided to obtain the necessary clearances. Open cubicle doors shall not restrict the movement of the circuit breakers or the ground and test devices. Doors or bolted access plates shall be provided on the rear of the cable termination compartments.
- 3.4. All doors and panels shall be fabricated of not less than 11 gauge, smooth surfaced, sheet steel reinforced with structural steel shapes as required for proper rigidity. Doors shall have concealed hinges, three point latching system and foot operated door holders. Pistol grip door handles shall be provided.
- 3.5. All instruments, drawout case type relays, control switches, and indicating lamps shall be mounted and arranged on the front of the panels for operating aisle viewing.
- 3.6. A minimum operating aisle of 6'-0" shall be provided in front of the switchgear.
- 3.7. Cable entrance compartments shall provide adequate space for up to two sets of 13.2 kV or 33kV cable terminations. Field installed insulated boots or taping shall be furnished to cover the cable terminations.
 - 3.7.1. BGE incoming supply feeder cable terminations will be furnished and installed by BGE.
- 3.8. Each incoming supply feeder cable compartment shall be equipped with mounting provisions for three (3) BGE surge arresters. Arresters will be furnished and installed by BGE. The location of the arresters shall not interfere with the installation by BGE of the incoming supply feeder cable terminations. Shop drawings shall include details of the surge arresters mounting facilities.

BGE
STRATEGIC CUSTOMER ENGINEERING

PRIMARY CUSTOMER SUBSTATION REQUIREMENTS
13.2 KV METAL-CLAD SERVICE ENTRANCE SWITCHGEAR
FOR USE ON THE AREA NETWORK SYSTEM

GUIDE SPECIFICATION CSR-4

REVISION No. 1 – January, 2005

- 3.8.1. For 13.2 kV service, BGE surge arresters will be 10 kV duty cycle, 8.4 kV MCOV metal-oxide distribution class.
- 3.8.2. Mounting details of the BGE surge arresters are included in this specification.
- 3.9. The phase arrangement in the switchgear assembly shall be A, B, and C from left to right, top to bottom, and front to back, when viewed from the front of the switchgear. The phase arrangement of the circuit breakers poles, current transformers, and all accessories shall be shown on the switchgear drawings.
- 3.10. At panel shipping splits, where necessary, terminal blocks shall be provided in each panel for the wiring connections across the split. One end of such wires shall be connected into the terminal block on one panel and the remainder coiled, with each lead being clearly marked for field connection to the adjacent panel.
- 3.11. The design of all switchgear assemblies shall be such that no appreciable inductive heating will occur when carrying either the continuous load or the intermittent load. Adequate ventilation shall be provided for ultimate expansion.
- 3.12. Each switchgear unit shall be equipped with screened ventilation louvers as required by the design of the switchgear assembly.
- 3.13. The floor area directly beneath the center phase cable terminations shall not have structural supports.
- 3.14. The switchgear units shall be equipped with heaters to maintain air circulation and prevent condensation inside the enclosure.
- 3.14.1. Heaters shall be equipped with guards providing both thermal and electric shock protection to personnel. Heater wiring must be of the type capable of withstanding the high temperature environment in the proximity of the heaters.
- 3.14.2. Heaters shall be wired to one main fused safety switch or circuit breaker in the switchgear. Heaters shall operate continuously, without the application of a thermostat, unless a humidistat is also provided in the heater control to operate the heaters during high humidity weather regardless of temperature.

BGE
STRATEGIC CUSTOMER ENGINEERING

PRIMARY CUSTOMER SUBSTATION REQUIREMENTS
13.2 KV METAL-CLAD SERVICE ENTRANCE SWITCHGEAR
FOR USE ON THE AREA NETWORK SYSTEM

GUIDE SPECIFICATION CSR-4

REVISION No. 1 – January, 2005

3.15. Outdoor Installations

- 3.15.1. A walk-in weatherproof housing shall be furnished to accommodate the switchgear assembly, including any required miscellaneous equipment. The entire outdoor housing shall include an operating aisle space of sufficient size to permit withdrawal of the circuit breakers for inspection, test or maintenance. An access door shall be located at each end of the aisle and arranged so that the door can be opened from the inside regardless of whether or not it has been padlocked on the outside. Indoor lighting and receptacles, heating and ventilation equipment shall be provided as required or specified.
- 3.15.2. Heaters shall be provided in each switchgear cubicle in accordance with 3.14 above.
- 3.15.3. The switchgear outdoor housing shall be insect and rodent proof.
- 3.15.4. Where a **substation fence** is specified, the fence shall be 8' high minimum, made of 7' metal fabric and topped with a 1' height of barbed wire, unless otherwise approved by BGE.
- 3.15.4.1. A 3'-0" personnel gate shall be provided and shall be equipped with double padlocking facilities.
- 3.15.4.2. The substation fence shall be connected to the substation grounding system in accordance with this Section 11 in this specification.
- 3.15.4.3. High voltage warning signs shall be provided on each access gate and on all sides of the fence enclosure.
- 3.15.4.4. Where applicable, the fenced area in outdoor substations shall be filled with 3/4" crushed stone to a minimum depth of 4". The top of the stone shall be approximately level with the top of the concrete pad supporting the switchgear.
- 3.15.4.5. Where the substation is located adjacent to roadways, loading docks, parking areas, or any area susceptible to damage from vehicular traffic, pipe guards or barriers shall be installed around the substation area to protect the fence or the electrical equipment. The pipe guards or barriers shall not interfere with opening the doors of the switchgear units. Metal pipe guards

BGE
STRATEGIC CUSTOMER ENGINEERING

PRIMARY CUSTOMER SUBSTATION REQUIREMENTS
13.2 KV METAL-CLAD SERVICE ENTRANCE SWITCHGEAR
FOR USE ON THE AREA NETWORK SYSTEM

GUIDE SPECIFICATION CSR-4

REVISION No. 1 – January, 2005

shall be connected to the substation grounding system in accordance with Section 10 in this specification.

4. CIRCUIT BREAKER

- 4.1. Circuit breakers shall be oil-less, 3-pole, single-throw, electrically operated, having mechanical stored energy operating mechanisms. Breakers shall be designed for service on a three phase, 60 Hz system. The continuous current capacity of the circuit breakers shall be as required to satisfactorily operate within the specified duties. Breakers shall be equipped with a manual-operating device for manually closing and manually opening the contacts. All circuit breakers of the same ampere rating in the switchgear assembly shall be similar and interchangeable.

Circuit breakers shall have the following ratings:

Nominal voltage class, kV, rms	13.2
Rated maximum voltage, kV, rms	15.0
Rated voltage range factor, kV	1.3
Nominal 3-Phase MVA Class, MVA, not less than	500
Insulated level, rated withstand voltage:	
Low frequency, kV, rms, not less than	36
Impulse, kV, crest, not less than	95
Rated frequency, hertz	60
Maximum rated interrupting time (60 Hz base), cycles	5
Rated continuous current, amperes, not less than	1200
Rated short-circuit current, kA, rms, symmetrical	18
Maximum interrupting capacity, kA, rms, symmetrical	23
Three second short-time current carrying capability, kA, rms	23
Closing and latching capability, kA, rms	37

- 4.2. Circuit breakers shall be furnished with a stored energy operating mechanism mounted on the breaker frame. The operating mechanism shall form a part of the removable elements and shall be designed for trip and close operation from a nominal source of 48 or 125 volts, dc, ungrounded. The control equipment shall be designed so that a momentary closing signal will cause complete closing of the breaker. Breakers shall be trip-free and non-pumping.
- 4.3. Each circuit breaker shall be of the removable type, designed for convenience in handling, and furnished with guides and stops for accurate alignment of the removable element in the housing. A mechanism shall be provided to change the position of the

BGE
STRATEGIC CUSTOMER ENGINEERING

PRIMARY CUSTOMER SUBSTATION REQUIREMENTS
13.2 KV METAL-CLAD SERVICE ENTRANCE SWITCHGEAR
FOR USE ON THE AREA NETWORK SYSTEM

GUIDE SPECIFICATION CSR-4

REVISION No. 1 – January, 2005

removable element with respect to the connected and disconnected positions in the housing. This mechanism shall be interlocked with the circuit breaker operating mechanism to prevent insertion or withdrawal of the removable element except when the breaker is in the open position. The position-changing mechanism shall be arranged for manual operation with the breaker compartment door closed, and interlocked so that the power drive, if furnished, is disconnected before the manual operator can be utilized.

- 4.4. Each circuit breaker shall be furnished with primary and secondary disconnecting devices, accurately located and securely mounted to maintain proper alignment at all times. Provisions shall be made for the test operation of any circuit breaker in its compartment only when the breaker is in the disconnected position.
- 4.5. Where SF6 interrupter bottles are furnished, a low-pressure alarm switch shall be furnished for each interrupter bottle.

5. SWITCHGEAR EQUIPMENT

- 5.1. **Instrument Transformers** (Except revenue-metering transformers provided by BGE in accordance with Section 9 in this specification)

- 5.1.1. All current transformers shall be designed, manufactured, and tested in accordance with ANSI standards. Current transformers shall be dry type and shall be furnished and installed in each assembly as required. Secondary leads of all current transformers shall be terminated on shorting type terminal blocks with non-insulated ring tongue type terminals.
- 5.1.2. All potential transformers shall be designed, manufactured, and tested in accordance with ANSI standards. Potential transformers shall be dry type and shall be furnished in the switchgear assembly as required. The maximum ratio and phase angle errors, when carrying full secondary burdens, shall not exceed standard classifications. The manufacturer shall determine that the actual volt-ampere burdens are within the thermal ratings and accuracy of the transformer. Primary current limiting fuses shall be provided for transformer protection.
 - 5.1.2.1. Potential transformers required for incoming voltage sensing may be connected on the source side of the main incoming breakers. Installation of potential transformers on the source side of the main incoming breakers (for incoming voltage sensing only), including transformer fuse protection and grounding facilities, shall be in accordance with Section 5.1.3.

BGE
STRATEGIC CUSTOMER ENGINEERING

PRIMARY CUSTOMER SUBSTATION REQUIREMENTS
13.2 KV METAL-CLAD SERVICE ENTRANCE SWITCHGEAR
FOR USE ON THE AREA NETWORK SYSTEM

GUIDE SPECIFICATION CSR-4

REVISION No. 1 – January, 2005

- 5.1.3. **Potential transformer** shall have a full wave impulse level of 95 kV BIL. Potential transformers shall be mounted on a drawout unit, complete with current limiting fuses. The drawout units shall be designed to automatically ground the potential transformer primary and disconnect the secondary when the drawout unit is withdrawn from the compartment. The secondary disconnect devices shall be of a rugged, positive contact design. Secondary disconnect devices shall be visible and accessible when the unit is withdrawn.
- 5.1.3.1. The drawout unit shall latch in both the fully withdrawn position and fully closed position.
- 5.1.3.2. The metal frame of the drawout unit shall be grounded in all positions
- 5.1.3.3. Potential transformer primary grounding facilities shall be approved by BGE prior to fabrication. Grounding facilities shall provide a positive ground connection with the drawout unit in the fully withdrawn and latched position. Braided grounding straps, which merely brush the fuse primary terminals, are not acceptable. Shop drawings shall show sufficient details of the grounding facilities. Field approval by BGE of the potential transformer primary grounding facilities shall be required prior to energizing the service entrance switchgear.
- 5.1.3.4. Automatic shutters shall be provided to isolate the drawout unit from the bus connection in the compartment. The shutters shall open when the fuse drawout unit moves forward into the connected position, and shall close when the drawout unit is withdrawn.
- 5.1.3.5. Potential transformer primary current limiting fuses shall be readily accessible with the drawout unit in the fully withdrawn and latched position. When fuses are mounted horizontally, they shall not be more than 5' above finished floor line. On vertical or tilt-out mountings, the top fuse clip shall not be more than 6' above finished floor line.
- 5.1.4. **Control power transformers** (if required) shall be connected on the load side of the main incoming breakers and on the load side of the BGE revenue metering equipment. Control power transformers shall not be connected on the source side of the BGE revenue metering equipment. Control power transformers shall be designed, manufactured and tested in accordance with ANSI standards. Transformers shall be dry type, single-phase or three-phase, as required. A

BGE
STRATEGIC CUSTOMER ENGINEERING
PRIMARY CUSTOMER SUBSTATION REQUIREMENTS
13.2 KV METAL-CLAD SERVICE ENTRANCE SWITCHGEAR
FOR USE ON THE AREA NETWORK SYSTEM
GUIDE SPECIFICATION CSR-4
REVISION No. 1 – January, 2005

minimum of two full current non-load primary taps, one above and one below the nominal rating are recommended. Primary current limiting fuses shall be provided for transformer protection.

5.1.4.1. Control power transformers for 13.2 kV service shall be mounted on a drawout unit, complete with current limiting fuses. The drawout unit shall latch in both the fully withdrawn position and fully closed position. An automatic shutter shall be provided which opens when the drawout unit moves forward to the connected position and closes when it is withdrawn. The drawout unit shall be interlocked with a circuit breaker on the secondary side so that the load must be removed from the transformer before the unit can be withdrawn. The drawout unit shall be designed to automatically ground the transformer primary and disconnect the secondary when the unit is withdrawn. Fuses shall be readily accessible with the drawout unit in the fully withdrawn and latched position.

5.2. **Meters, Instruments, and Relays** (Except the revenue meters provided by BGE in accordance with Section 9 in this specification).

5.2.1. All meters, instruments, and relays shall be standard switchboard type for mounting on steel panels.

5.2.2. Protection for the main incoming breakers shall be provided by inverse current type relays. The time-current characteristic and settings are subject to BGE approval. The main breaker overcurrent relays shall be equipped with instantaneous trip, unless bus differential protection is furnished which provides instantaneous overcurrent protection. Main breaker overcurrent relays shall be approved by BGE prior to fabrication of the switchgear.

5.2.2.1. If the protective relay on the main incoming breaker is of the induction disc type, settings will be provided by the Customer along with supporting evidence in the form of a coordination study approved by BGE in accordance with Section 13 in this specification. The approved original settings will be applied by the Customer and verified through secondary current injection test by BGE prior to energizing the switchgear.

5.2.2.2. If the protective relay on the main incoming breaker is a micro-processor based device, settings will be provided by the Customer along with supporting evidence in the form of a coordination study approved by BGE in accordance with Section 13 in this specification. The original settings will be applied by

BGE
STRATEGIC CUSTOMER ENGINEERING

PRIMARY CUSTOMER SUBSTATION REQUIREMENTS
13.2 KV METAL-CLAD SERVICE ENTRANCE SWITCHGEAR
FOR USE ON THE AREA NETWORK SYSTEM

GUIDE SPECIFICATION CSR-4

REVISION No. 1 – January, 2005

the Customer and verified through secondary injection test by BGE. The micro-processor based protective relay shall be set to operate the main incoming breakers only. Any programmed logic shall be designed so that current injection testing of the overcurrent tripping function shall not trip any other device. BGE shall only verify the overcurrent tripping function. In the event that the relays must be re-calibrated, the Customer shall provide the software and/or technical assistance required to apply the new settings. BGE shall not be responsible for maintaining the software or device-specific equipment required for calibrating a micro-processor based relay. Any microprocessor based protective relay shall provide an alarm to indicate relay failure.

5.2.2.3. The main breaker overcurrent relays shall be mounted in drawout cases to facilitate current injection without removing the relays from their cases. Where the relays are not mounted in drawout cases, appropriate current test switches shall be provided to facilitate testing the relays by current injection without removing the relays from their fixed mounted cases. The design of the test switch facilities shall be approved by BGE.

5.2.3. Bus differential protection may be provided in the switchgear in lieu of instantaneous overcurrent relay elements. Bus differential relays shall provide instantaneous overcurrent tripping of the main incoming breakers and outgoing feeder breakers for a switchgear bus fault. The application of bus differential protection will facilitate better coordination between the main incoming feeder time-overcurrent relays and the outgoing feeder overcurrent relays for outgoing feeder faults.

5.2.4. Additional protective relays, such as directional overcurrent relays, pilot wire relays, or transformer differential relays, shall be provided as required by the Customer and/or BGE.

5.3. Control and Instrument Switches

5.3.1. All control and instrument switches shall be switchboard type, and of rotary type heavy duty construction. Switches shall be mounted on the hinged front doors of the breaker and auxiliary compartments, unless otherwise indicated.

5.3.2. Ammeter switches shall not be permitted on the main incoming breaker overcurrent relay current transformer circuits. If ammeters are required on these current circuits, three ammeters shall be furnished. Alternately, separate current

BGE
STRATEGIC CUSTOMER ENGINEERING

PRIMARY CUSTOMER SUBSTATION REQUIREMENTS
13.2 KV METAL-CLAD SERVICE ENTRANCE SWITCHGEAR
FOR USE ON THE AREA NETWORK SYSTEM

GUIDE SPECIFICATION CSR-4

REVISION No. 1 – January, 2005

transformers may be furnished for metering only, independent of the current transformer protective relay circuits.

5.4. Battery and Charger

5.4.1. A battery system having a nominal output voltage of 48 or 125 volts DC, shall be provided for circuit breaker trip and close control power.

5.4.2. Sufficient battery capacity shall be provided to carry all control and relay loads for 8 hours and then perform the greatest switchgear duty, such as tripping all circuit breakers simultaneously, or closing a minimum of two breakers in the switchgear assembly, with the battery charger de-energized.

5.4.3. A regulated battery charger shall be provided with silicon controlled full wave rectification, silicon diodes, and replaceable plug-in type control units. The charger shall be designed to prevent the discharge of the battery in case of an ac power failure or any charger malfunction.

5.4.3.1. The charger shall include circuit breaker protection on both the ac input and dc output circuits. Charger circuit breakers shall not be overloaded or tripped when recharging a fully discharged battery or under a short-circuit at the charger output terminals.

5.4.3.2. The charger shall be equipped with current limiting circuits, high-voltage shutdown circuit, transient and surge voltage protection, ground detection alarm light, ac pilot light, dc voltmeter connected to the battery side of the charger, and low dc voltage alarm relay with remote alarm indication.

6. MAIN AND GROUND BUS

6.1. Main Bus

6.1.1. The main bus and taps shall have minimum rated continuous current of 1200 amperes unless otherwise specified, or as required by the Customer load.

6.1.2. Main bus and taps shall be rigid, of high conductivity copper or aluminum, with all joints plated. Main bus and bus taps shall be fully insulated. All bus connections shall be made up of with at least two bolts not less than 3/8" diameter or one bolt not less than 1/2" diameter. All bus connections shall be bolted and torqued by

BGE
STRATEGIC CUSTOMER ENGINEERING

PRIMARY CUSTOMER SUBSTATION REQUIREMENTS
13.2 KV METAL-CLAD SERVICE ENTRANCE SWITCHGEAR
FOR USE ON THE AREA NETWORK SYSTEM

GUIDE SPECIFICATION CSR-4

REVISION No. 1 – January, 2005

approved methods to insure maximum conductivity.

- 6.1.3. The thermal and mechanical stress ratings of the buses shall be such as to make them capable of withstanding short-circuit currents equal to the momentary rating of connected breakers in the switchgear assembly.
- 6.1.4. The main bus supports and stub connection supports shall be high impact strength, non-hygroscopic, non-porous approved material, and shall have sufficient mechanical strength to withstand, without damage, the stresses produced by a short-circuit current equal to the momentary current rating of connected breakers in the switchgear assembly. Each bus section shall be supported at not less than two points to maintain proper alignment.
- 6.1.5. The temperature rise of buses and connections shall not exceed ANSI requirements. Provisions shall be made for expansion and contraction of buses due to temperature changes.
- 6.1.6. The minimum nominal 3-Phase MVA Class of the switchgear assembly shall be 500MVA for 13.2 kV service.
- 6.1.7. The minimum BIL rating of the switchgear assembly shall be 95 kV impulse withstand for 13.2 kV service.

6.2. Ground Bus

- 6.2.1. A continuous copper ground bus shall extend through and connect to all units of the switchgear assembly.
- 6.2.2. The ground bus shall be capable of withstanding the short circuit stresses associated with the maximum momentary rating of any circuit breaker in the section through which the bus extends. The ground bus shall not be smaller than 2" x 1/4".
- 6.2.3. The ground bus shall be securely bonded and run through the entire switchgear assembly. Each section of the assembly shall be grounded directly to the switchgear ground bus.
- 6.2.4. Ground bus joints shall be plated and made up with at least two bolts not less than 3/8" diameter or one bolt not less than 1/2" diameter. Provisions shall be made

BGE
STRATEGIC CUSTOMER ENGINEERING

PRIMARY CUSTOMER SUBSTATION REQUIREMENTS
13.2 KV METAL-CLAD SERVICE ENTRANCE SWITCHGEAR
FOR USE ON THE AREA NETWORK SYSTEM

GUIDE SPECIFICATION CSR-4

REVISION No. 1 – January, 2005

for extension of the ground bus to future switchgear units, as applicable.

- 6.2.5. The switchgear ground bus shall be connected at each end to the substation grounding system in accordance with Section 10 in this specification. The switchgear manufacturer shall provide a minimum of two 2-hole NEMA drilled compression type terminal lugs, suitable for connection of a 4/0 AWG station grounding wire, for the Customer to make the ground connections to the substation grounding system.
- 6.2.6. The ground bus and respective ground connectors shall be capable of carrying the rated short-circuit current.
- 6.2.7. Ground connections shall be provided for all removable elements.
- 6.2.8. Cases of frames of instruments, meters, relays, instrument transformers and similar devices shall be considered as being adequately grounded when secured to the metal structure by metal mounting screws with adequate provision for penetrating the mounting structure paint film by the mounting hardware..
- 6.2.9. Ground contact shall be provided in the breaker compartments to engage the grounding and test device, which shall be furnished in accordance with Section 7 in this specification.
- 6.2.10. Grounding devices approved by BGE for the attachments of portable grounding equipment shall be provided in the ground and test device in accordance with Section 7 in this specification.
- 6.2.11. Grounding devices approved by BGE for the attachments of portable grounding equipment shall be provided in each BGE revenue-metering unit in accordance with Section 10 of this specification.

7. GROUND AND TEST DEVICE

- 7.1. One or two manually operated ground and test device(s) shall be furnished with the switchgear assembly. The devices shall be equipped with facilities for testing and grounding either the bus side or feeder side of any circuit breaker compartment. The ground and test devices shall be approved by BGE.
- 7.2. The manual ground and test device shall be equipped with six bushings in the same configuration as the circuit breaker. The bushings shall engage stationary contacts of the

BGE
STRATEGIC CUSTOMER ENGINEERING

PRIMARY CUSTOMER SUBSTATION REQUIREMENTS
13.2 KV METAL-CLAD SERVICE ENTRANCE SWITCHGEAR
FOR USE ON THE AREA NETWORK SYSTEM

GUIDE SPECIFICATION CSR-4

REVISION No. 1 – January, 2005

incoming and outgoing feeder, or the bus terminals in each breaker compartment. The opposite ends of the six bushings shall be terminated in two totally enclosed compartments identified and labeled as **BUS** and **FEEDER** connection.

- 7.3. Where the switchgear is furnished with a one-high breaker arrangement, with a single circuit breaker in each switchgear unit, only one ground and test device will be required. The relationship of BUS and FEEDER connections shall always be the same whether the ground and test device is used in an incoming or outgoing feeder breaker compartment.
- 7.4. Where the switchgear is furnished in a two-high breaker arrangement, with lower and upper breaker compartments in each switchgear unit, one or two ground and test devices will be required in accordance with paragraphs 7.4.1 or 7.4.2 below.
- 7.4.1. If one ground and test device is furnished, the device shall be provided with special interlocks to prevent inserting the device in any breaker compartment unless its BUS – FEEDER relationship corresponds to that in the breaker compartment. Interlocks shall also prevent changing the BUS – FEEDER relationship of the device once it is inserted in the breaker compartment. The actual BUS – FEEDER relationship on the device shall be clearly indicated at anytime, before and after inserting the device in any breaker compartment.
- 7.4.2. If two ground and test devices are furnished, one device shall be clearly marked with the BUS – FEEDER relationship for the upper breaker compartment, and the other device shall be clearly marked with the BUS – FEEDER relationship for the lower breaker compartment. Special interlocks shall be provided to prevent inserting the device in any breaker compartment unless its BUS – FEEDER relationship corresponds to that in the breaker compartment.
- 7.5. Each compartment in the ground and test device containing the BUS and FEEDER connections shall have non-removable doors. The two doors shall be capable of remaining open simultaneously. Each compartment door shall be equipped with padlocking facilities. Padlocking facilities shall be arranged such that there is no interference between the padlocks and the switchgear compartment. Hinged compartment doors shall have captive fasteners, such as wing nuts or sliding bars, to prevent easy access to energized bushings, whether or not the padlocks are in place.
- 7.6. Insulating barriers shall be provided on all walls of the bushing compartments and around each of the BUS and FEEDER phase bushings, with adequate electrical clearances to correspond with the voltage and BIL ratings of the switchgear. Physical clearances in each ground and test device compartment shall be such as to allow the

BGE
STRATEGIC CUSTOMER ENGINEERING

PRIMARY CUSTOMER SUBSTATION REQUIREMENTS
13.2 KV METAL-CLAD SERVICE ENTRANCE SWITCHGEAR
FOR USE ON THE AREA NETWORK SYSTEM

GUIDE SPECIFICATION CSR-4

REVISION No. 1 – January, 2005

convenient attachment of the grounding leads used by BGE to the required, appropriate grounding devices in each compartment.

- 7.7. All six bushings (3 BUS & 3 FEEDER) shall be equipped with grounding devices capable of accommodating portable grounding lead clamps used by BGE. A 3/4” diameter copper grounding bar shall be attached to the front of the ground and test device for grounding the other end of the portable grounding leads. The grounding bar shall be easily accessible and not interfering with the doors on either the BUS or FEEDER compartment. The grounding bar shall be connected to a separate grounding contact on the ground and test device that shall connect to the main ground bus in the switchgear compartment. All contact surfaces, including those for application of portable grounding clamps, shall be plated.
- 7.8. The ground and test device or devices shall be stored in switchgear compartments provided as part of the switchgear assembly.
- 7.9. Complete shop drawings of the ground and test device or devices shall be submitted to BGE for review and approval prior to fabrication of the switchgear. Approved ground and test device or devices shall be furnished with the switchgear assembly. Field approval by BGE of the actual devices shall be required prior to energizing the service entrance switchgear. BGE shall not energize the service entrance switchgear unless BGE approved ground and test device or devices are made available to BGE personnel at the time of energizing the switchgear.
- 7.10. Details showing the typical arrangement of the grounding and test device are included in this specification.
- 7.11. A current listing of manufacturers of ground and test devices approved by BGE is available upon request. Presently, BGE has approved the following manufacturers of acceptable ground and test devices:
- General Electric
 - Cutler-Hammer
(Westinghouse)
 - Siemens
 - Powercon Toshiba
 - Square D
- 7.11.1. Ground and test devices from other switchgear manufacturers will be considered subject to approval by BGE in accordance with paragraph 7.9 above.

BGE
STRATEGIC CUSTOMER ENGINEERING

PRIMARY CUSTOMER SUBSTATION REQUIREMENTS
13.2 KV METAL-CLAD SERVICE ENTRANCE SWITCHGEAR
FOR USE ON THE AREA NETWORK SYSTEM

GUIDE SPECIFICATION CSR-4

REVISION No. 1 – January, 2005

8. SWITCHGEAR CONTROL WIRING

- 8.1. Each switchgear unit shall be completely wired at the factory and shall be ready for external connections. Similar units shall be wired alike.
- 8.2. All control and current circuit wiring shall be type SIS, or approved equal. Wiring shall be stranded, insulated switchboard wire. The wire gage shall be # 14 AWG or larger, depending upon the ampacity of the circuit.
- 8.3. Wires #10 AWG and smaller shall be terminated with noninsulated ring tongue type terminals. Wires larger than #10 AWG shall be terminated with noninsulated lugs with inspection holes.
- 8.4. Neutrals of current and potential transformers shall be wired to terminal blocks.
- 8.5. All control wires shall be identified at each end with permanent tags marked to agree with the drawing designations.
- 8.6. Terminal blocks and termination points shall not have more than two wires connected to any point. Terminal blocks shall be provided with white marking strips. Where used for current transformer connections, the terminal blocks shall be of the shorting type, and shall be equipped with a cover.
- 8.7. A termination point at the end of the switchgear assembly shall be provided for a 48V or 125V, dc, 2-wire ungrounded source of control power. The termination point of the main dc control power circuit shall be connected to a disconnect switch. Control power taps to each switchgear compartment shall be fused from the main dc control circuit within each switchgear unit.
- 8.8. Exposed wiring, where used, shall be formed into compact groups, suitably bound together and supported, using straight horizontal and vertical runs with short radius right angle bends. There shall be no taps or splices in the wiring. All connections shall be made to terminal blocks or on the equipment.
- 8.9. At panel shipping splits, terminal blocks shall be provided in each panel for the wiring connections across the split. One end of such wires shall be connected into the terminal block on one panel and the remainder coiled with each lead clearly marked for field connection to the terminal block on the adjacent panel.

BGE
STRATEGIC CUSTOMER ENGINEERING

PRIMARY CUSTOMER SUBSTATION REQUIREMENTS
13.2 KV METAL-CLAD SERVICE ENTRANCE SWITCHGEAR
FOR USE ON THE AREA NETWORK SYSTEM

GUIDE SPECIFICATION CSR-4

REVISION No. 1 – January, 2005

8.10. Special wiring requirements in the BGE metering units shall be provided in accordance with Section 9 in this specification.

9. BGE REVENUE METERING UNIT

9.1. General Requirements Metering Units

- 9.1.1. The BGE revenue metering units in the switchgear assembly shall contain provisions for mounting the BGE revenue metering current and potential transformers, and potential transformer fuses, including all necessary drilling and bolting hardware.
- 9.1.2. Each metering unit shall be provided with front doors. Doors shall also be provided where access to the rear of the BGE metering cubicle is required. Doors shall be as specified in paragraph 3.4 above. Metering unit doors shall be equipped with pistol handles having provisions for padlocking. Padlocks for the metering unit doors will be furnished by BGE.
- 9.1.3. The revenue metering current transformers, potential transformers, and potential transformer fuses will be furnished and installed by BGE. The quantity, rating, make and type of the metering current transformers, potential transformers and potential transformer fuses will be specified by BGE for each Customer installation.
- 9.1.4. BGE will furnish and install three (3) current transformers, three (3) potential transformers, and three (3) potential transformer fuses in each revenue-metering unit, unless otherwise specified by BGE for a particular Customer installation.
- 9.1.5. All primary connections from the switchgear bus to the current transformer terminals, from the switchgear bus to the potential transformer fuses, and from the fuses to the potential transformers shall be provided and installed by the switchgear Manufacturer.
- 9.1.6. Primary connections between the switchgear bus and the current transformers shall have the same continuous current rating as the main switchgear bus.
- 9.1.7. Primary taps from the switchgear bus to the potential transformer fuses shall be connected to the switchgear bus on the **supply** side terminals of the current transformer primary bus connections.

BGE
STRATEGIC CUSTOMER ENGINEERING

PRIMARY CUSTOMER SUBSTATION REQUIREMENTS
13.2 KV METAL-CLAD SERVICE ENTRANCE SWITCHGEAR
FOR USE ON THE AREA NETWORK SYSTEM

GUIDE SPECIFICATION CSR-4

REVISION No. 1 – January, 2005

9.1.8. All primary cable connections to the switchgear bus shall be made with two-bolt compression type connectors.

9.2. Grounding Requirements

9.2.1. Grounding devices for the attachments of portable grounding equipment shall be provided where specified below. Grounding devices shall be approved by BGE.

9.2.2. Grounding devices on both sides of the 13.2 kV current transformer bus connections shall be provided. Grounding devices shall be readily accessible and securely attached to the switchgear bus so as not to interfere with, nor have to be removed during the installation, removal, or replacement of the current transformers.

9.2.3. Grounding devices on the primary leads from the potential transformer fuses to the 13.2 kV potential transformers shall be provided. Grounding devices shall be readily accessible and securely attached to bus supports so as not interfere with the installation, removal, or replacement of the potential transformers.

9.2.4. Grounding devices shall be provided on the ground bus, or ground bus extensions into the current or potential transformer compartments. Grounding devices shall be readily accessible and within the reach of the BGE portable ground leads to be attached by BGE on the grounding devices on both sides of the current transformers or on the primary leads to the potential transformers.

9.2.4.1. Details of the grounding devices are included in this specification. Alternate designs will be considered subject to approval by BGE prior to fabrication and certified by test to withstand the short circuit stresses associated with the short-circuit rating of the switchgear.

9.2.4.2. There shall be adequate clearance for the metering cubicle door to be closed with the portable ground leads in place.

9.3. Drawout Fuse Unit

9.3.1. A fuse drawout unit complete with fuse clips mounted on insulators shall be provided in a completely isolated compartment to accommodate three potential transformers fuses.

BGE
STRATEGIC CUSTOMER ENGINEERING

PRIMARY CUSTOMER SUBSTATION REQUIREMENTS
13.2 KV METAL-CLAD SERVICE ENTRANCE SWITCHGEAR
FOR USE ON THE AREA NETWORK SYSTEM

GUIDE SPECIFICATION CSR-4

REVISION No. 1 – January, 2005

- 9.3.2. Fuse clips for 13.2 kV service shall be mounted on 11-1/2” centers to accommodate current limiting fuses having 1-9/16” diameter ferrules, similar to GE “EJ-1”, Size “B”, 15 kV, 1.0E ampere.
- 9.3.3. When fuses in the drawout unit are mounted horizontally, they shall be not more than 5’ above finished floor. If mounted vertically, the top fuse clip shall not be more than 6’ above finished floor.
- 9.3.4. The fuse drawout unit shall latch in both the fully withdrawn position and fully closed position.
- 9.3.5. The fuse drawout unit shall be designed so that all contacts will be disconnected from the energized circuits before the fuses become accessible. Both ends of the fuses shall be visibly grounded when the drawout unit is in the fully withdrawn and latched position.
- 9.3.6. Automatic shutters shall be provided to isolate the drawout unit from the bus connection in the compartment. The shutters shall open when the fuse drawout unit moves forward into the connected position, and shall close when the drawout unit is withdrawn.
- 9.3.7. The metal frame of the drawout unit shall be grounded in all positions.
- 9.3.8. The fuse drawout unit grounding facilities shall be approved by BGE prior to fabrication. Grounding facilities shall provide a positive ground connection with the unit in the fully and latched position. Braided grounding straps, which merely brush the fuse primary terminals, are not acceptable. Shop drawings shall show sufficient details of the grounding facilities. Field approval by BGE of the fuse drawout unit grounding facilities shall be required prior to energizing the service entrance switchgear.
- 9.3.9. The front of the drawout unit shall be provided with padlocking facilities, unless the drawout unit assembly is located behind a padlockable door.
- 9.3.10. The switchgear ground bus shall be extended and mounted in the front of each current and potential transformer compartment. A grounding device shall be mounted on the ground bus extension in each compartment.

BGE
STRATEGIC CUSTOMER ENGINEERING

PRIMARY CUSTOMER SUBSTATION REQUIREMENTS
13.2 KV METAL-CLAD SERVICE ENTRANCE SWITCHGEAR
FOR USE ON THE AREA NETWORK SYSTEM

GUIDE SPECIFICATION CSR-4

REVISION No. 1 – January, 2005

9.3.11. Should interphase barriers be necessary to isolate each fuse unit they shall have no less than 6 inch overlap all around. Barriers shall not interfere with the application of grounds on both ends of the fuse and shall be sturdily mounted to prevent misalignment or incidental contact with any energized part.

9.4. Metering Unit

9.4.1. Three (3) Current Transformers will be provided by BGE for revenue metering of each 13.2 kV incoming supply feeder. The BGE revenue metering current transformers will have the same dimensions as the GE type JKM-5.

9.4.2. A completely isolated compartment shall be provided in the metering unit for the installation by BGE of the three revenue metering current transformers.

9.4.3. Three (3) Potential Transformers will be provided by BGE for revenue metering of each 13.2 kV incoming supply feeder. The BGE revenue metering potential transformers will have the same dimensions as the GE type JVM-5.

9.4.4. A completely isolated compartment shall be provided in the metering unit for the installation by BGE of the three revenue metering potential transformers.

9.4.5. The compartments shall be arranged to allow for the easy access, installation, removal, or replacement of the revenue metering current and potential transformers after the metering unit is installed as an integral part of the switchgear assembly.

9.4.6. Each metering unit compartment housing the potential and current transformers shall be provided with an interior protective hinged screen barrier or metal panel to prevent inadvertent physical contact with any energized part with the metering cubicle door open. The interior hinged screen barrier or metal panels shall be bolted closed with captive fasteners or other acceptable latching devices.

9.4.7. Grounding devices shall be provided in accordance with paragraph 9.2 above.

9.4.8. The switchgear ground bus shall be extended and mounted in the front of each current and potential transformer compartment. A grounding device shall be mounted on the ground bus extension in each compartment.

BGE
STRATEGIC CUSTOMER ENGINEERING

PRIMARY CUSTOMER SUBSTATION REQUIREMENTS
13.2 KV METAL-CLAD SERVICE ENTRANCE SWITCHGEAR
FOR USE ON THE AREA NETWORK SYSTEM

GUIDE SPECIFICATION CSR-4

REVISION No. 1 – January, 2005

9.4.9. Three (3) current limiting fuses will be provided by BGE for protection of each revenue metering potential transformer.

9.4.10. Typical arrangement of the 13.2 kV metering cubicle is included in this specification.

9.5. Secondary Wiring

9.5.1. Secondary wiring from the current and potential transformers shall be provided by the switchgear manufacturer. Secondary wiring shall be extended and connected to terminal blocks in each metering unit. Adequate slack shall be provided for BGE to make the final connections to the metering transformers secondary terminals.

9.5.2. Secondary wiring shall be type SIS or approved equal, stranded, insulated switchboard wire of minimum #12 gage. Wires shall be equipped with ring tongue type terminals at each end. Wiring shall be installed in metal conduit or where shielded wires are used, they shall be bundled and appropriately supported on the compartment walls. Insulating bushings are to be installed when wiring between adjacent compartments or through barriers and partitions.

9.5.3. All six secondary leads from each set of metering current transformers shall be extended and connected to a shorting type terminal block. All six secondary leads from each set of potential transformers shall be extended and connected to a terminal block. Terminal blocks in each metering unit shall be mounted on the side wall of the unit, adjacent to the meter panel specified above. Terminal blocks shall be readily accessible from the front of the meter panel compartment in the switchgear unit.

9.5.3.1. Where a remote meter cabinet is required in accordance with paragraph 9.6 below, the terminal blocks in each metering unit shall be located near the termination of the 2-inch conduit to be provided by the Customer in accordance with paragraph 9.5.4 below. Terminal blocks shall be readily accessible from the front of the metering units in the switchgear.

9.5.3.2. Terminal blocks shall be Marathon 6000DJ, Buchanan B-112, or equal approved by BGE.

9.5.4. For a split bus configuration a 2-inch diameter conduit shall be provided between the revenue metering units in the switchgear assembly. The ends of the conduit

BGE
STRATEGIC CUSTOMER ENGINEERING

PRIMARY CUSTOMER SUBSTATION REQUIREMENTS
13.2 KV METAL-CLAD SERVICE ENTRANCE SWITCHGEAR
FOR USE ON THE AREA NETWORK SYSTEM

GUIDE SPECIFICATION CSR-4

REVISION No. 1 – January, 2005

shall be terminated in each revenue meter panel compartment near the location of the terminal blocks specified above.

- 9.5.5. Secondary wiring between the terminal blocks specified above and the revenue meter panel in the switchgear or the remote meter cabinet, will be furnished and installed by BGE.

9.6. Remote Metering Cabinet

- 9.6.1. The remote meter cabinet will be provided by BGE for installation by the Customer. Remote meter cabinets will be 36”W x 60”H x 13”D. The required quantity of the remote meter cabinets will be specified by BGE for each Customer installation. Generally, one remote meter cabinet will be required for one or two supply feeders.
- 9.6.2. The location of each remote meter cabinet shall be shown on the drawings and shall be readily accessible and as close as possible to the switchgear metering unit. A minimum 5-foot clearance shall be required in front of the meter cabinet. The location of the remote meter cabinet, or cabinets, shall be approved by BGE prior to installation by the Customer.
- 9.6.3. Where a separate meter panel is required a 2-inch diameter conduit shall be provided by the Customer from each metering cubicle in the switchgear assembly to the location of the remote meter cabinet. Where more than one meter cabinet is required, a 2-inch diameter conduit shall be provided between the meter cabinets. Conduits may be rigid tubing, rigid non-metallic, or electrical metallic tubing, as permitted by NEC for the specific customer installation. A maximum of two 90° elbows shall be used. Where the 2” conduit is in excess of 50’ special requirements will be necessary.
- 9.6.4. Details of the BGE meter cabinet, termination of the conduits and grounding provisions are included in this specification.

9.7. Telephone Connection

- 9.7.1. A dedicated telephone line shall be provided by the Customer for remote revenue metering by BGE. The telephone line shall be brought to the remote revenue metering cabinet by the customer. BGE will terminate the line in the cabinet.

BGE
STRATEGIC CUSTOMER ENGINEERING

PRIMARY CUSTOMER SUBSTATION REQUIREMENTS
13.2 KV METAL-CLAD SERVICE ENTRANCE SWITCHGEAR
FOR USE ON THE AREA NETWORK SYSTEM

GUIDE SPECIFICATION CSR-4

REVISION No. 1 – January, 2005

9.7.2. The Customer shall supply BGE with a telephone number capable of being called at any time for remote revenue metering by BGE.

9.7.3. The telephone line shall consist of a 4/C - two twisted pair - telephone cable in a 3/4" minimum conduit. The telephone cable shall be #24 AWG solid copper, UL type CMP, or better if required by NEC.

10. SUBSTATION GROUNDING SYSTEM

10.1. A driven ground rod system consisting of copperclad steel or stainless steel ground rods shall be provided by the Customer in the substation area. The ground rods shall be interconnected with minimum 4/0 AWG bare stranded copper or copperclad wire to form a grid system.

10.2. The substation grounding system, shall be tested by industry accepted methods in accordance with Section 14 in this specification. The measured ground resistance shall not exceed 5 ohms.

10.3. All non-current carrying metal parts and equipment in the substation area shall be connected to the grounding system.

10.4. The switchgear ground bus shall be connected to the substation grounding system at each end with minimum 4/0 AWG bare stranded copper wire, in accordance with paragraph 6.2.5 above.

10.5. Where a remote meter cabinet is required in accordance with paragraph 9.6 above, a minimum 1/0 AWG bare stranded copper wire shall be extended from the substation grounding system to the location of the remote meter cabinet, with 3 feet of free length for grounding the cabinet.

10.6. Exothermic joints shall be used for all connections below grade. Double-bolted compression type connectors shall be used for above ground connections to substation equipment.

10.7. Where metal pipe guards or barriers are required for vehicular traffic protection in the substation area each metal pipe guard or barrier shall be connected to the grounding system with a minimum 1/0 AWG bare stranded copper wire.

BGE
STRATEGIC CUSTOMER ENGINEERING

PRIMARY CUSTOMER SUBSTATION REQUIREMENTS
13.2 KV METAL-CLAD SERVICE ENTRANCE SWITCHGEAR
FOR USE ON THE AREA NETWORK SYSTEM

GUIDE SPECIFICATION CSR-4

REVISION No. 1 – January, 2005

- 10.8. Where a substation fence is provided by the Customer the fence shall be connected to the substation grounding system.
- 10.8.1. As a minimum, every other fence post shall be connected to the grounding system with a minimum 1/0 AWG bare stranded copper or copperclad wire located 2'-6" outside the substation fence, and buried 12" below grade.
- 10.8.2. The substation fence gates shall be equipped with a flexible braided ground strap at the hinged end.
- 10.9. Typical substation grounding grid details are included in this specification.

11. TRANSFORMER

Three-phase transformer shall have the following ratings:

Rated primary voltage, V, rms	13,200
Rated secondary voltage, V, rms	(*)
Insulation level, rated withstand voltage:	
Impulse (BIL), kV, crest, not less than	95
Rated frequency, hertz	60
Minimum Impedance on Transformer base	4 %

(*) As required by the Customer's secondary system.

- 11.1. Network transformers shall be rated 13,200 volts with two 2.5% high voltage taps above and below the rating of 13,200 volts. Basic Insulation Level (BIL) rating shall be 95 kV, and the impedance shall not be less than 4%. Either Delta or Wye transformation is acceptable by the Baltimore Gas and Electric Company. A three pole group operated disconnecting and grounding switch shall be provided on the high voltage side of each network transformer. The switch shall be interlocked to prevent operation of the switch when the transformer is energized. The network transformers shall be designed, constructed, and tested in accordance with the applicable provisions of the ANSI and NEMA Standards. Shop drawings for the network transformers shall be submitted to the Baltimore Gas and Electric Company for approval.
- 11.2. Transformer shall be equipped with full capacity, manual control, primary taps for de-energized operation. Two 2.5% taps above and two 2.5% taps below the rated primary

BGE
STRATEGIC CUSTOMER ENGINEERING

PRIMARY CUSTOMER SUBSTATION REQUIREMENTS
13.2 KV METAL-CLAD SERVICE ENTRANCE SWITCHGEAR
FOR USE ON THE AREA NETWORK SYSTEM

GUIDE SPECIFICATION CSR-4

REVISION No. 1 – January, 2005

voltage shall be provided.

- 11.3. Transformer windings may be connected DELTA-WYE or WYE-WYE.
- 11.4. 13,200 volt, 3-phase, 4-wire, 60 hertz, WYE system with the neutral solidly grounded at multiple locations, including the Customer facility.
- 11.5. The transformer shall be built in accordance with the latest applicable industry standard for the specific class of apparatus.
- 11.6. A transformer nameplate shall be provided in accordance with the latest ANSI standard showing all pertinent information, including a connection diagram and vector diagram showing all windings, taps, removable links, terminals, etc., KVA, insulation and temperature rise class, BIL ratings, voltage ratio taps, and impedance.

12. SECONDARY NETWORK PROTECTORS

- 12.1. Secondary network protectors shall consist of a three pole motor operated circuit breaker with shunt trip, network master relay, network phasing relay, non-reset operation counter and a mechanical position indicator. Network protectors shall be equipped with Y-Type Burndy Fuse Links, as required.
- 12.2. Network protectors shall open on overload, fault current, ground fault, and reverse power flow, as determined by the Short Circuit and Coordination Study. Network protectors must be capable of being tripped manually under any conditions. Network protectors shall close when conditions are such that true poly-phase power will flow from the transformer to the network.
- 12.3. Network protectors shall conform to all the applicable requirements of the ANSI and NEMA Standards, the Underwriter's Laboratories, and the National Electrical Code. Shop drawings for the network protectors shall be submitted to the Baltimore Gas and Electric Company for approval.
- 12.4. The customer shall be responsible to perform routine testing and preventive maintenance on all 13.2 kV incoming feeder breakers and all secondary network protectors as required by the Baltimore Gas and Electric Company and as recommended by the equipment manufacturer. Incoming feeder breakers and secondary network protectors shall be maintained by the customer at intervals not to exceed three years and

BGE
STRATEGIC CUSTOMER ENGINEERING

PRIMARY CUSTOMER SUBSTATION REQUIREMENTS
13.2 KV METAL-CLAD SERVICE ENTRANCE SWITCHGEAR
FOR USE ON THE AREA NETWORK SYSTEM

GUIDE SPECIFICATION CSR-4

REVISION No. 1 – January, 2005

one year respectively, or whenever operating indications deem it advisable. Overhauls shall be performed in accordance with manufacturer's recommendations. A certificate of completion of this work, signed by a responsible official of the firm which performed the overhaul, shall be forwarded to the Baltimore Gas and Electric Company.

13. SHORT-CIRCUIT AND COORDINATION STUDY

- 13.1. **REQUIRED SUBMITAL:** A coordination study is required to be submitted to BGE for review and approval
- 13.2. A short-circuit and coordination study shall be prepared by the Customer. The study shall include a system one line diagram and impedance one line diagram. The study shall include the proposed ampere rating and time-current characteristic of the power or electronic fuses. Where a fixed mounted circuit breaker is furnished, the study shall include the proposed protective relay characteristic and settings.
- 13.3. The study shall include coordination curves showing the specific time-current characteristics of each protective device plotted in such manner that all upstream devices, including BGE protective devices (where applicable), will be clearly depicted on a single sheet.
- 13.4. Available short-circuit currents or impedances of the BGE system supplying the Customer, and time-current characteristics and settings of the BGE protective devices on the supply feeders shall be requested from BGE prior to preparing the study.
- 13.5. Proposed time-current characteristics and ampere ratings of the power or electronic fuses and, if applicable, the protective relay time-current characteristics and settings of the fixed mounted circuit breakers in the service entrance switchgear are subject to BGE approval. Copy of the study shall be submitted to BGE for approval prior to fabrication of the switchgear.

14. INSPECTIONS AND TESTS PRIOR TO ENERGIZING PRIMARY CUSTOMER SUBSTATIONS

- 14.1. **REQUIRED SUBMITTAL:** Certificate of Electrical Inspection
- 14.1.1. A certificate of electrical inspection covering all new service entrance equipment, or reconnection of a modified or relocated existing service entrance equipment, shall be obtained by the Customer from the local inspection authority having jurisdiction. A copy of the inspection certificate shall be forwarded to BGE before

BGE
STRATEGIC CUSTOMER ENGINEERING

PRIMARY CUSTOMER SUBSTATION REQUIREMENTS
13.2 KV METAL-CLAD SERVICE ENTRANCE SWITCHGEAR
FOR USE ON THE AREA NETWORK SYSTEM

GUIDE SPECIFICATION CSR-4

REVISION No. 1 – January, 2005

such equipment may be energized by BGE.

14.1.2. On State or Federal government projects, where the local inspection authority would have no jurisdiction, a “**Letter of Exemption**” covering approval of the installation will be acceptable in lieu of the inspection certificate. The letter shall be signed by an agent authorized by the State of Maryland – Fire Marshal and forwarded to BGE before the service entrance equipment may be energized by BGE. A copy of the letter and list of authorized agents will be provided upon request.

14.2. Field Inspection and Tests to be Provided by the Customer

14.2.1. Field tests to be provided by the Customer shall be performed by a qualified testing company, such as a certified International Electrical Testing Association (NETA) member, and meet the NETA Maintenance Testing Specifications for Electrical Power Distribution Equipment and Systems.

14.2.2. A written report of the field tests shall be forwarded to BGE to demonstrate compliance with this requirement before the service entrance equipment may be energized by BGE.

14.2.3. The measured ground resistance of the substation grounding system, in accordance with Section 10 in this specification, shall not exceed five ohms. Record of the measured ground resistance shall be included in the written report to be forwarded to BGE.

14.2.4. High potential tests of the service entrance equipment shall be made by the testing company as near as possible to the scheduled service date.

14.2.4.1. **NOTE: This test is only valid for a period of 30 days**

It will be necessary to re-test the switchgear if more than 30 days elapse between the date of the high potential tests and the date for energizing the switchgear.

14.2.5. It shall be the Customer responsibility to test the automatic transfer system to assure satisfactory operation. BGE personnel will witness the test in accordance with 14.3.10 below.

BGE
STRATEGIC CUSTOMER ENGINEERING

PRIMARY CUSTOMER SUBSTATION REQUIREMENTS
13.2 KV METAL-CLAD SERVICE ENTRANCE SWITCHGEAR
FOR USE ON THE AREA NETWORK SYSTEM

GUIDE SPECIFICATION CSR-4

REVISION No. 1 – January, 2005

14.2.6. It is the Customer's responsibility to inspect and test the entire Customer owned substation installation prior to energizing, and periodically thereafter.

14.2.7. Where bus differential relays are provided, the Customer shall test and wire check the bus differential relays.

14.2.8. Where directional relays are provided, the Customer shall test and wire check the directional relays.

14.2.9. Where pilot wire relays are provided, The Customer shall test and wire check the pilot wire relays.

14.3. Inspection and Tests to be Provided by BGE.

14.3.1. Prior to energizing the Customer owned substation, BGE will perform an initial inspection of the Customer service entrance equipment. This inspection is to safeguard the public and assure a safe working environment for BGE; however, it is not intended to be a complete Customer installation check.

14.3.2. If for any reason the Customer service entrance equipment is not installed in a manner acceptable to BGE, and in accordance with good engineering practices and applicable laws, regulations and codes, and this specification, then following such initial inspection and before energizing the equipment for permanent use, the Customer shall make such modifications or repairs as may be required by BGE. The Customer shall notify BGE when the required modifications are completed.

14.3.3. In Customer substations where two or more incoming supply feeders are installed, BGE will make live high voltage phase-out tests between the incoming feeders.

14.3.4. BGE will wire check the control wiring from the main breaker overcurrent tripping current transformers to the protective overcurrent relays and to the breaker tripping coils.

14.3.5. **Required Submittal:** Final "as-built" control wiring diagram drawings shall be furnished to BGE for review and approval before BGE can perform the wire check. BGE will not energize the Customer substation until the "as-built" drawings are furnished by the Customer.

BGE
STRATEGIC CUSTOMER ENGINEERING

PRIMARY CUSTOMER SUBSTATION REQUIREMENTS
13.2 KV METAL-CLAD SERVICE ENTRANCE SWITCHGEAR
FOR USE ON THE AREA NETWORK SYSTEM

GUIDE SPECIFICATION CSR-4

REVISION No. 1 – January, 2005

- 14.3.6. BGE will bring to the attention of the Customer any problems found in the protective overcurrent relay control wiring for correction by the Customer. After the required wiring problems have been corrected by the Customer, BGE will complete the wire check.
- 14.3.7. BGE will verify the main overcurrent relay settings through secondary current injection test.
- 14.3.8. Where directional relays and pilot wire relays are provided, BGE will verify the settings and operation of the relays as required.
- 14.3.9. BGE will electrically test trip the main breaker overcurrent relays from the corresponding protective equipment.
- 14.3.10. The Baltimore Gas and Electric will test the operation of all secondary network protectors at least once per month by de-energizing supply feeders one at a time. There is no charge for these tests.

15. REQUIRED SUBMITTALS:

- 15.1. The following is a summary of the documents requiring approval by BGE as indicated in this specification:
- 15.1.1. Preliminary drawings and specifications covering the primary Customer substation. This shall include the service entrance switchgear equipment installation, incoming cable conduits, telephone circuit for remote BGE metering, substation transformers, and grounding facilities.
- 15.1.2. Manufacturer's shop drawings for the entire service entrance switchgear assembly, including but not limited to, load interrupter switches and protective fuse equipment or fixed mounted circuit breakers, grounding details of drawout fuse units, BGE metering units and grounding devices, and schematic and control wiring diagram drawings where applicable.
- 15.1.3. Short-circuit and coordination study.
- 15.1.4. Manufacturer's "as-built" shop drawings for the entire service entrance switchgear assembly, including but not limited to, schematic and control wiring diagrams.

BGE
STRATEGIC CUSTOMER ENGINEERING

PRIMARY CUSTOMER SUBSTATION REQUIREMENTS
13.2 KV METAL-CLAD SERVICE ENTRANCE SWITCHGEAR
FOR USE ON THE AREA NETWORK SYSTEM

GUIDE SPECIFICATION CSR-4

REVISION No. 1 – January, 2005

15.1.5. **Certified Test Report** of the applicable inspections and tests to be performed by the Customer prior to energizing the service entrance switchgear.

15.1.6. **Certificate of Electrical Inspection** by the proper Code enforcing inspection authority, or a “Letter of Exemption” covering approval signed by an agent authorized by the State of Maryland – Fire Marshal. A copy of the authorization by the Fire Marshall must accompany the letter.

16. SCHEDULING & OUTAGE REQUESTS

The following represents the most typical sequence of events for scheduling the document approvals, outage requests, and cut-in of equipment.

16.1. Document Approvals:

- 16.1.1. Submit one-line and grounding drawings for approval (2 to 6 weeks turn around)
- 16.1.2. Submit equipment specification for approval (2 to 6 weeks turn around)
- 16.1.3. Submit coordination study for approval (2 to 6 weeks turn around)
- 16.1.4. Submit Manufacturer’s shop drawings for approval (2 to 6 weeks turn around)

16.2. Cut-in Procedures:

- 16.2.1. Customer to arrange for independent testing of the substation equipment
- 16.2.2. Customer to submit Certified Test Report for approval
- 16.2.3. Customer to arrange for electrical inspector to issue a “Certificate of Electrical Inspection” to BGE authorizing the energization of the substation equipment
- 16.2.4. Customer shall call responsible engineer to arrange for a precut-in meeting a minimum of two weeks prior to cut-in
- 16.2.5. During the precut-in meeting a service date will be established
- 16.2.6. **NOTE: a minimum of 10 work days are required to arrange for outages necessary to cut-in new equipment**

16.3. Outage Requests:

- 16.3.1. BGE Senior Key Account Engineers are responsible for obtaining outages at all primary service Customer substations. If you know who that person is you may call them direct. Otherwise the general number is 410-265-4086. This person will put you in touch with the Customer rep or handle the outage request directly.

BGE
STRATEGIC CUSTOMER ENGINEERING

PRIMARY CUSTOMER SUBSTATION REQUIREMENTS
13.2 KV METAL-CLAD SERVICE ENTRANCE SWITCHGEAR
FOR USE ON THE AREA NETWORK SYSTEM

GUIDE SPECIFICATION CSR-4

REVISION No. 1 – January, 2005

17. TYPICAL METAL-CLAD SERVICE ENTRANCE SWITCHGEAR
ARRANGEMENTS AND DETAILS

- 17.1. The following figures represent various typical arrangements of metal-clad switchgear for use as service entrance equipment on the BGE “Area Network” system, Ground and Test Device, BGE Surge Arresters, BGE Metering Units and Grounding Details.

BGE
STRATEGIC CUSTOMER ENGINEERING

PRIMARY CUSTOMER SUBSTATION REQUIREMENTS
13.2 KV METAL-CLAD SERVICE ENTRANCE SWITCHGEAR
FOR USE ON THE AREA NETWORK SYSTEM

GUIDE SPECIFICATION CSR-4

REVISION No. 1 – January, 2005

TYPICAL DESIGN FOR
PRIMARY NETWORK SERVICE

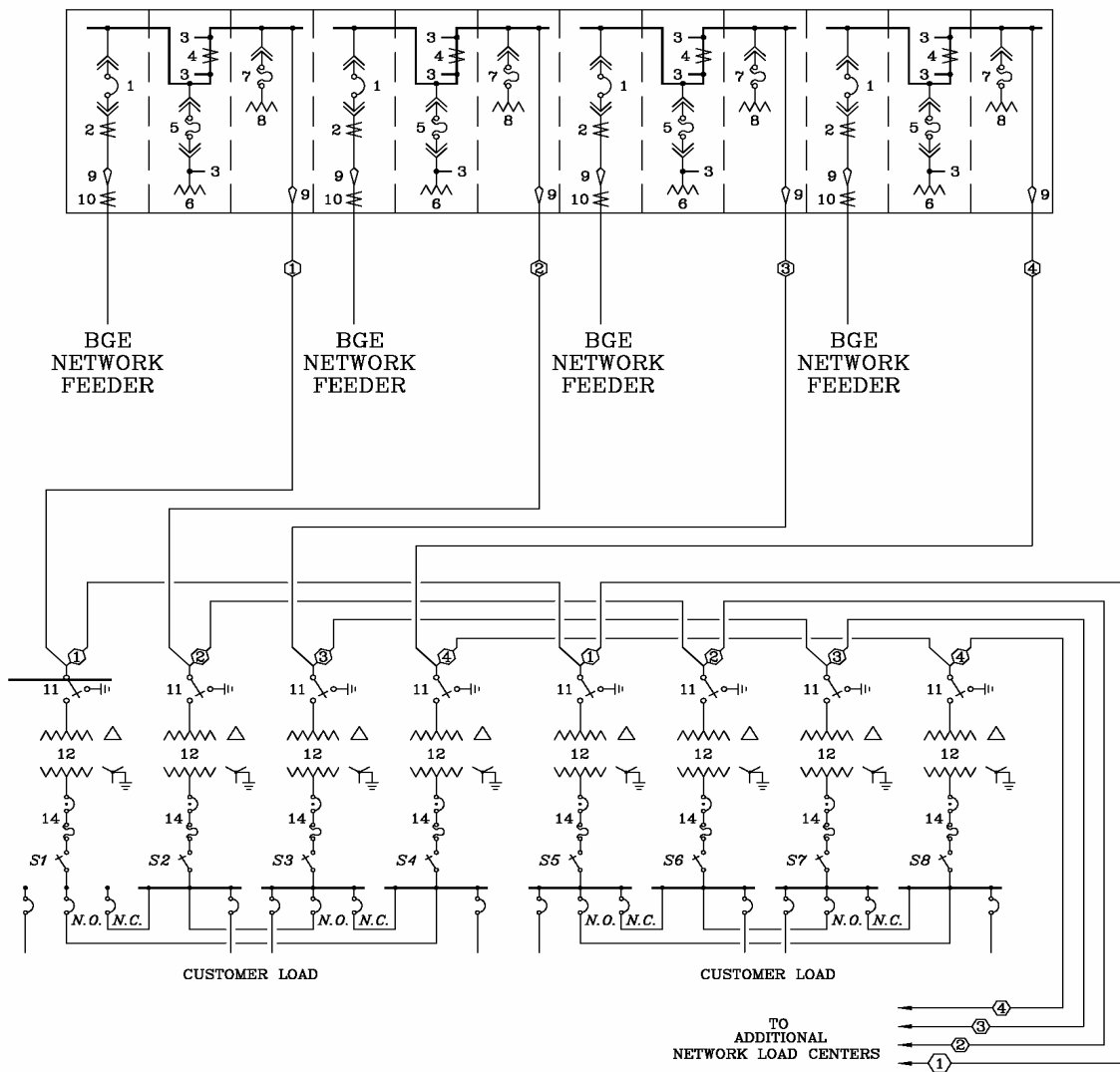

BGE
STRATEGIC CUSTOMER ENGINEERING

PRIMARY CUSTOMER SUBSTATION REQUIREMENTS
13.2 KV METAL-CLAD SERVICE ENTRANCE SWITCHGEAR
FOR USE ON THE AREA NETWORK SYSTEM

GUIDE SPECIFICATION CSR-4
 REVISION No. 1 – January, 2005

TYPICAL EQUIPMENT ASSOCIATED WITH
PRIMARY NETWORK SERVICE

1	1-ACB, WESTINGHOUSE TYPE "150-DHP-500", 1200 AMP, STORED ENERGY, 125 VOLT DC TRIP AND CLOSE
2	3-CURRENT TRANSF., WEST., "RCT-15", 600:5 AMP (FOR OVERCURRENT AND REVERSE CURRENT TRIP)
3	3-GROUND POINT
4	3-CURREN TRANSF., G.E., "JKM-110", 100:5 AMP, (FOR BGE REVENUE METER)
5	3-FUSE, GE TYPE "EJ-1", SIZE B, 1/2E AMP, (FOR BGE REVENUE METER)
6	3-POTENTIAL TRANSFORMER, GE TYPE "JVM-5", 70:1 VOLT, (FOR BGE REVENUE METER)
7	3-FUSE, WESTINGHOUSE TYPE "CLE-PT", 1/2E AMP
8	2-POTENTIAL TRANSF., WEST., "PTM-15", 14400-120 VOLT
9	3-CABLE TERMINATION
10	1-CURRENT TRANSF., WEST., "BYZ", 50:5 AMP, (FOR GROUND SENSOR TRIPPING)
11	1-HV 3 POSITION DEADBREAK DISCONNECT & GROUNDING SWITCH
12	1-TRANSFORMER, 1500 KVA, WESTINGHOUSE NETWORK TYPE, 13200-480/277 VOLT
13	1-TRANSFORMER, 2000 KVA, WESTINGHOUSE NETWORK TYPE, 13200-480/277 VOLT
14	1-NETWORK PROTECTOR, WESTINGHOUSE TYPE "CM-22", 2500 AMP, 480 VOLT, 60KA INTERRUPTING
15	1-NETWORK PROTECTOR, WESTINGHOUSE TYPE "CM-22", 3000 AMP, 480 VOLT, 60KA INTERRUPTING

BGE
STRATEGIC CUSTOMER ENGINEERING

PRIMARY CUSTOMER SUBSTATION REQUIREMENTS
13.2 KV METAL-CLAD SERVICE ENTRANCE SWITCHGEAR
FOR USE ON THE AREA NETWORK SYSTEM

GUIDE SPECIFICATION CSR-4

REVISION No. 1 - January, 2005

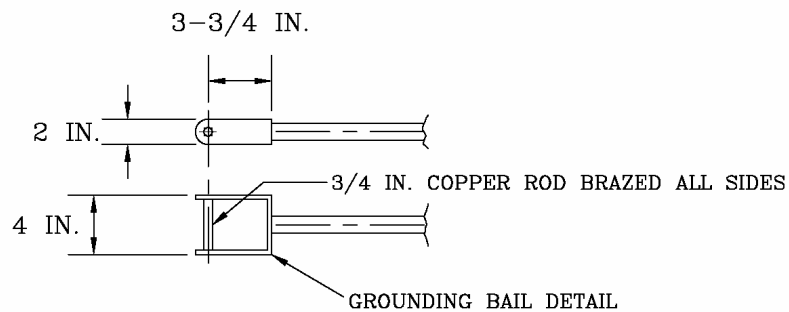
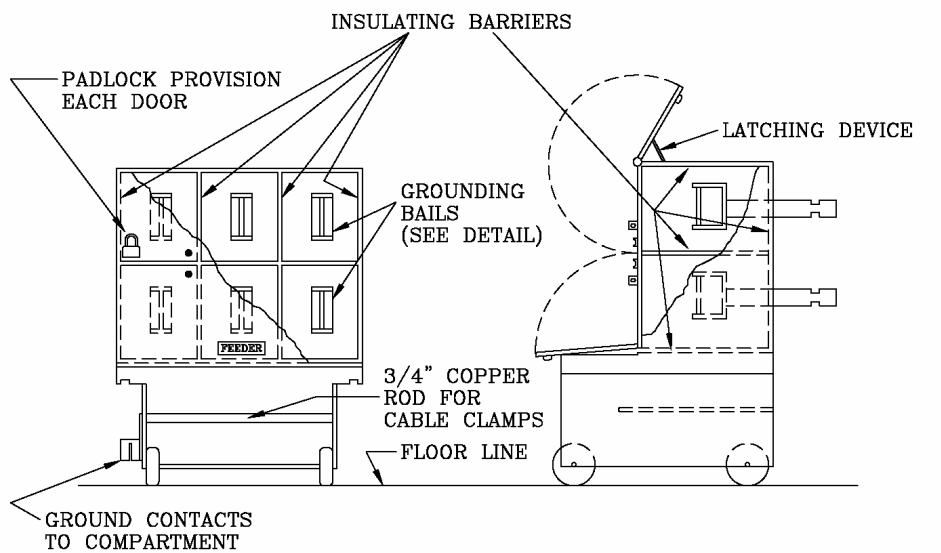

TYPICAL GROUNDING AND TEST DEVICE

BGE
STRATEGIC CUSTOMER ENGINEERING

PRIMARY CUSTOMER SUBSTATION REQUIREMENTS
13.2 KV METAL-CLAD SERVICE ENTRANCE SWITCHGEAR
FOR USE ON THE AREA NETWORK SYSTEM

GUIDE SPECIFICATION CSR-4

REVISION No. 1 – January, 2005

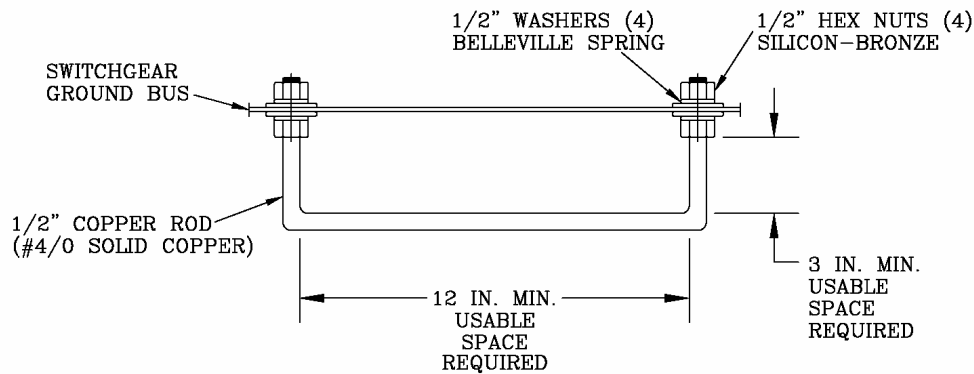

SWITCHGEAR GROUND BUS

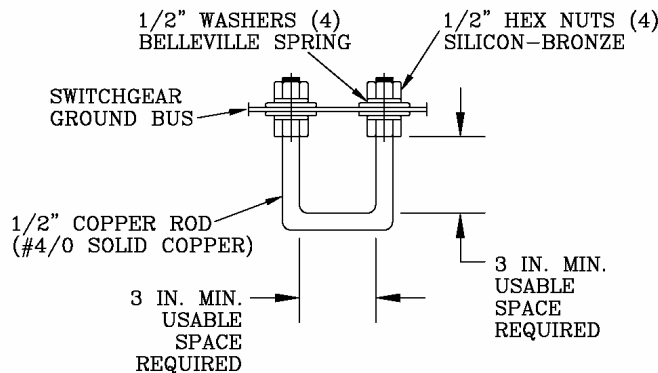

LINE & LOAD SIDE OF CURRENT TRANSFORMERS
LINE SIDE POTENTIAL TRANSFORMERS

ALTERNATE DESIGNS MAY BE CONSIDERED BY BGE PROVIDED THEY ARE APPROVED BY BGE PRIOR TO FABRICATION OF SWITCHGEAR AND THEY ARE CERTIFIED BY TEST TO WITHSTAND MOMENTARY RMS ASSYMETRICAL FAULT CURRENT RATING OF THE SWITCHGEAR.

GROUNDING DEVICES

BGE
STRATEGIC CUSTOMER ENGINEERING

PRIMARY CUSTOMER SUBSTATION REQUIREMENTS
13.2 KV METAL-CLAD SERVICE ENTRANCE SWITCHGEAR
FOR USE ON THE AREA NETWORK SYSTEM

GUIDE SPECIFICATION CSR-4

REVISION No. 1 – January, 2005

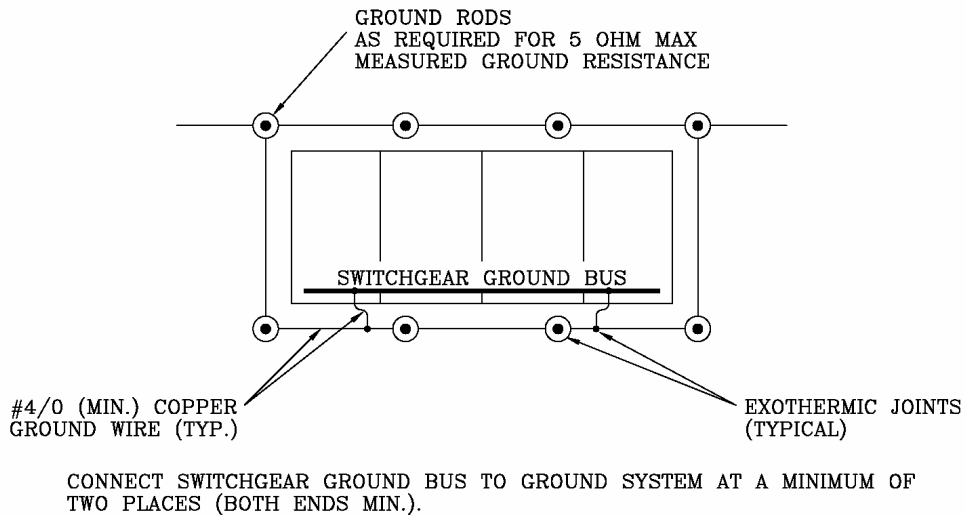

SWITCHGEAR GROUNDING

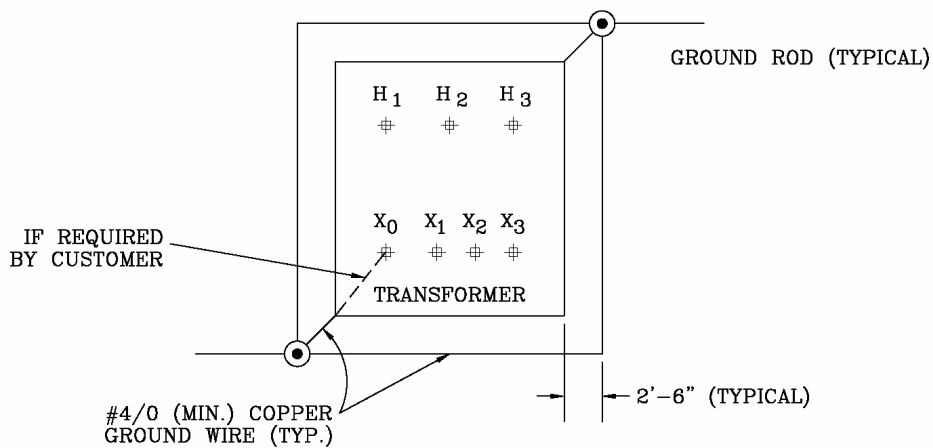

TRANSFORMER GROUNDING

BGE
STRATEGIC CUSTOMER ENGINEERING

PRIMARY CUSTOMER SUBSTATION REQUIREMENTS
13.2 KV METAL-CLAD SERVICE ENTRANCE SWITCHGEAR
FOR USE ON THE AREA NETWORK SYSTEM

GUIDE SPECIFICATION CSR-4

REVISION No. 1 - January, 2005

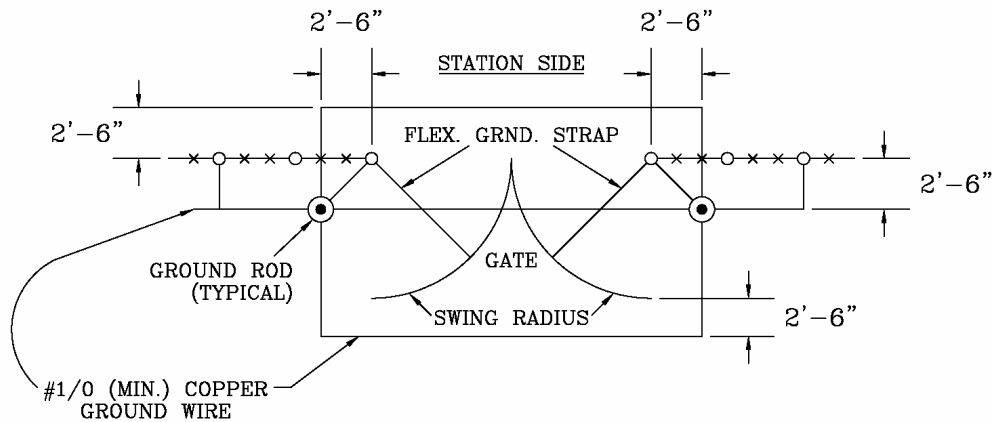
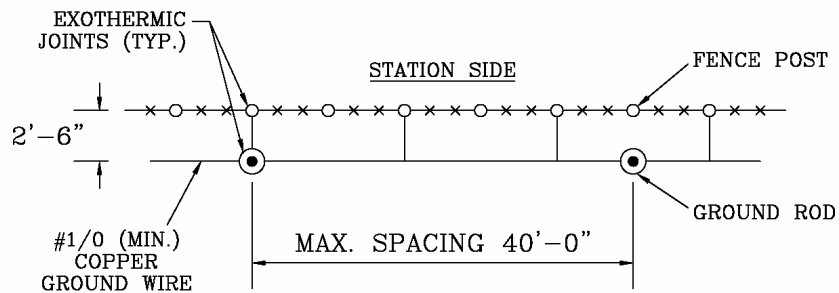

FENCE & GATE GROUNDING (IF APPLICABLE)
SUBSTATION GROUNDING DETAILS

BGE
STRATEGIC CUSTOMER ENGINEERING

PRIMARY CUSTOMER SUBSTATION REQUIREMENTS
13.2 KV METAL-CLAD SERVICE ENTRANCE SWITCHGEAR
FOR USE ON THE AREA NETWORK SYSTEM

GUIDE SPECIFICATION CSR-4

REVISION No. 1 – January, 2005

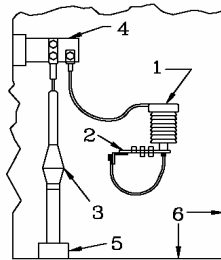

SIDE VIEW

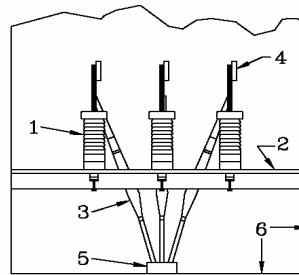

FRONT VIEW

NOTE: TYPICAL ARRANGEMENT SHOWN DOES NOT PRECLUDE OTHERS, SUBJECT TO BGE APPROVAL.

LEGEND

1. DISTRIBUTION CLASS METAL-OXIDE SURGE ARRESTERS BY BGE
2. REMOVABLE MOUNTING BRACKET BY CUSTOMER
3. INCOMING CABLE TERMINATIONS BY BGE
4. METAL-CLAD SWITCHGEAR INCOMING TERMINALS
5. 6 IN. DIAMETER RIGID NON-METALLIC CONDUITS BY CUSTOMER
6. INCOMING SUPPLY CABLE COMPARTMENT

BGE SURGE ARRESTERS

BGE
STRATEGIC CUSTOMER ENGINEERING

PRIMARY CUSTOMER SUBSTATION REQUIREMENTS
13.2 KV METAL-CLAD SERVICE ENTRANCE SWITCHGEAR
FOR USE ON THE AREA NETWORK SYSTEM

GUIDE SPECIFICATION CSR-4

REVISION No. 1 – January, 2005

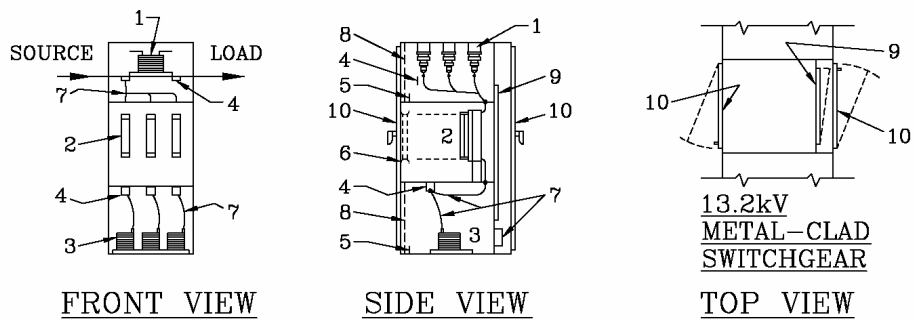

13.2kV
METAL-CLAD
SWITCHGEAR

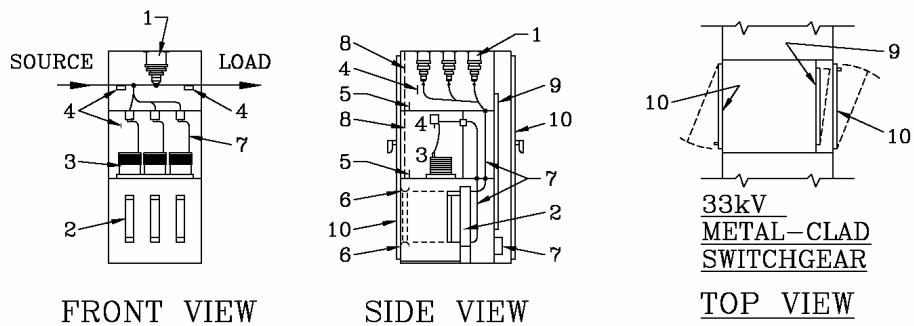

33kV
METAL-CLAD
SWITCHGEAR

TYPICAL ARRANGEMENTS FOR 13.2kV METERING UNIT

NOTE: TYPICAL ARRANGEMENT SHOWN DOES NOT PRECLUDE OTHERS, SUBJECT TO BGE APPROVAL.

LEGEND

- | | |
|------------------------------------|-----------------------------------|
| 1. BGE CURRENT TRANSFORMERS | 6. GROUNDING FINGERS (P.T. FUSES) |
| 2. BGE POTENTIAL TRANSFORMER FUSES | 7. CUSTOMER WIRING |
| 3. BGE POTENTIAL TRANSFORMERS | 8. HINGED SCREEN BARRIER |
| 4. GROUNDING BAILS (C.T. & P.T.) | 9. HINGED METER PANEL |
| 5. GROUNDING BAIL (GROUND BUS) | 10. PADLOCKABLE DOOR |

BGE
STRATEGIC CUSTOMER ENGINEERING

PRIMARY CUSTOMER SUBSTATION REQUIREMENTS
13.2 KV METAL-CLAD SERVICE ENTRANCE SWITCHGEAR
FOR USE ON THE AREA NETWORK SYSTEM

GUIDE SPECIFICATION CSR-4

REVISION No. 1 – January, 2005

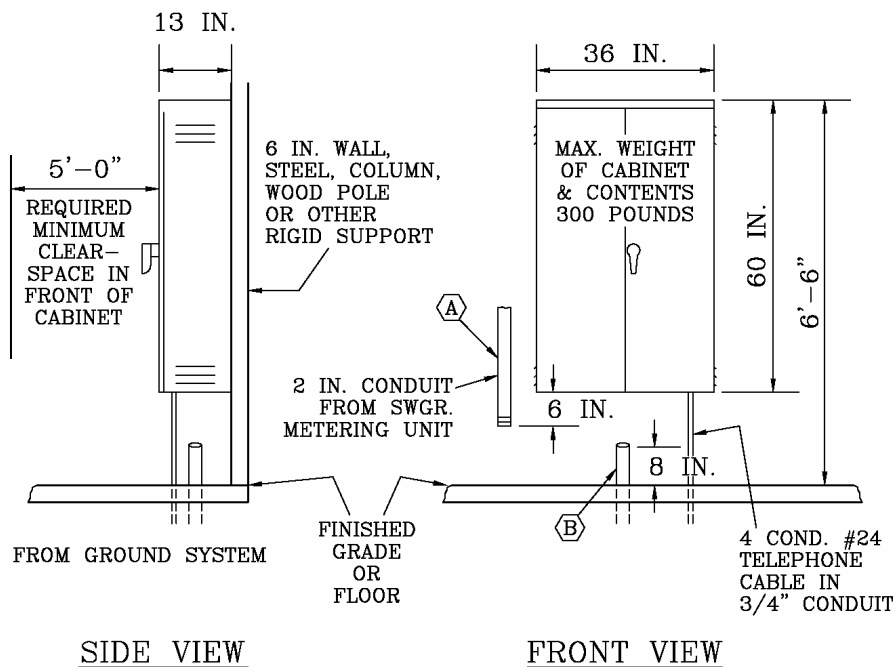

(A) TERMINATION BY CUSTOMER OF 2 IN. CONDUIT FOR ABOVE GROUND/FLOOR INSTALLATION.

(B) TERMINATION BY CUSTOMER OF 2 IN. CONDUIT FOR BELOW GROUND/FLOOR INSTALLATION.

1. CUSTOMER TO PROVIDE A 2 IN. DIAMETER CONDUIT (RIGID METAL, RIGID NON-METALLIC OR ELECTRICAL METALLIC TUBING, AS REQUIRED/PERMITTED BY NATIONAL ELECTRIC CODE.
2. CUSTOMER TO PROVIDE A 4/0 #24 AWG. SOLID COPPER (TWO TWISTED PAIR) TELEPHONE CABLE FROM CUSTOMER TELEPHONE SYSTEM (TO BE USED FOR REMOTE METERING).

BGE METER CABINET INSTALLATION
OUTDOOR / INDOOR